



# Who are we?

---

## Department of Engineering Sciences

### Division for Electricity and Lightning Research

- EMC and Lightning Group
- People involved in railway research
  - Prof. Rajeev Thottappillil
  - Dr. Nelson Theethayi
  - Daniel Månsson
  - Surajit Midya
  - Ziya Mazloom
  - PhD, Masters and exchange students from Tanzania, Switzerland, and Colombia



# Swedish Railway System



15 kV, 16 2/3 Hz traction power

22 kV, 50 Hz auxiliary power

DC track circuits

Communication cables

Multi-conductor transmission  
line modelling

# Objectives (2001-2005)

---

- Understand lightning interaction with railway system. Simulation tool
  - Role of ground resistivity in surge propagation and distribution
  - Measurements of lightning transients
  - Laboratory tests on equipments to find failure modes to transients
- (1 Ph.D. thesis, 1 Lic. thesis, 5 M.S thesis, 15 scientific publications)

# Objective (2006-2010)

---

- Develop validated models for EMI in electrified railway network and suggest mitigation methods.
- Investigate the new EMI issues that will come up as Banverket moves into ERTMS system and suggest solutions.



# Direct and Indirect Strikes [Lightning Attachment]

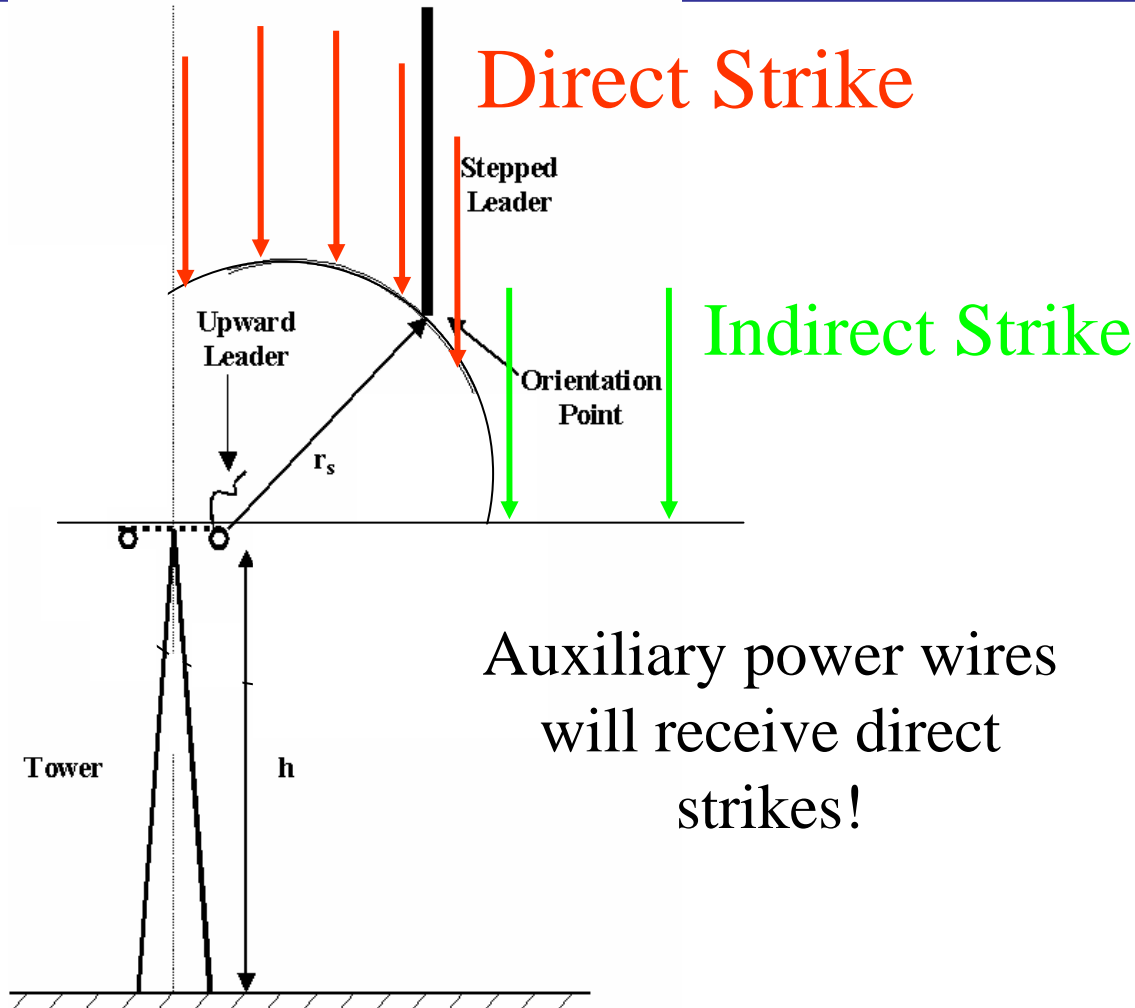

# Swedish railway above ground wires are different from power lines!

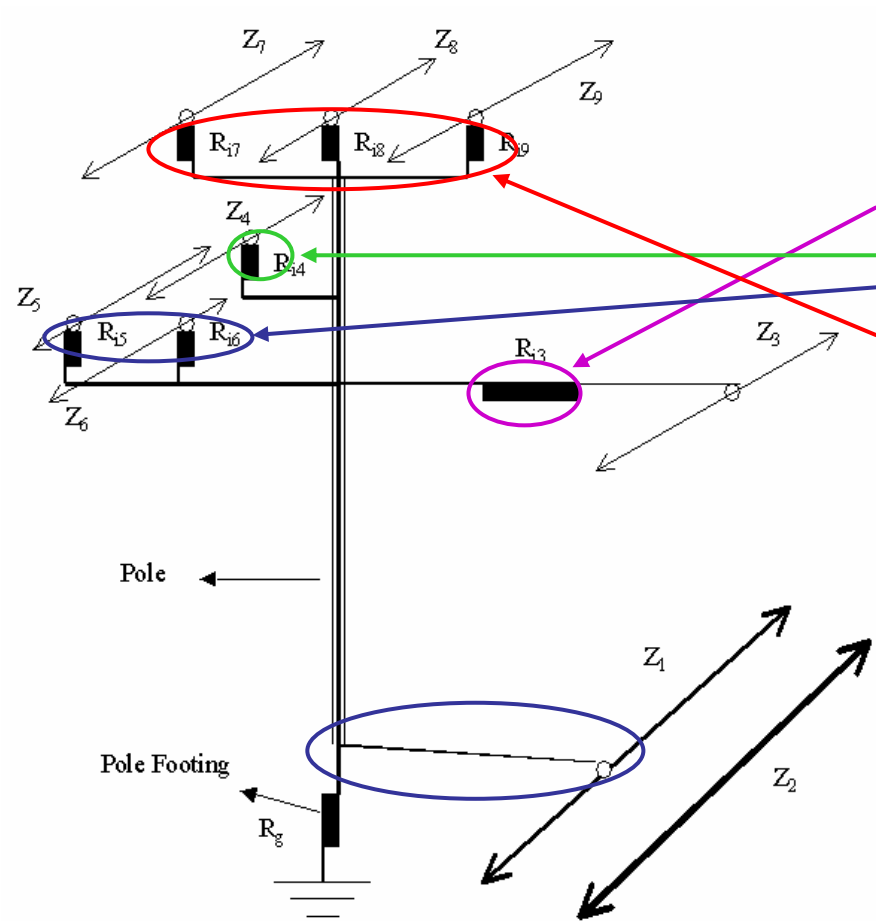

<i>Conductor Nomenclature</i>	<i>Ceramic Insulator Type</i>	<i>Impulse Withstand Voltage (kV)</i>
R3	Rod or Composit	225
R4	Lie post	170
R5 and R6	Spool	60
R7, R8 and R9	Pin	140

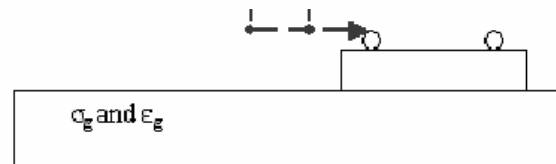

1. Conductors located at different heights
2. Every pole footing is connected to S-rail
3. Insulators on pole have different impulse withstand voltage (unique flashover at each pole)
4. At every 5km an interconnection exists between return conductors and S-rail

# Signal Circuits

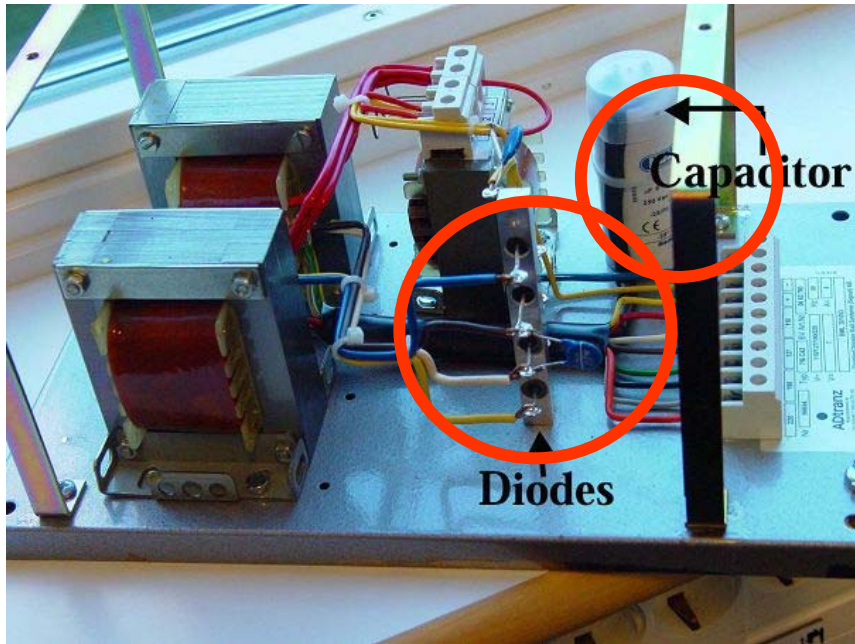

Rectifier Unit

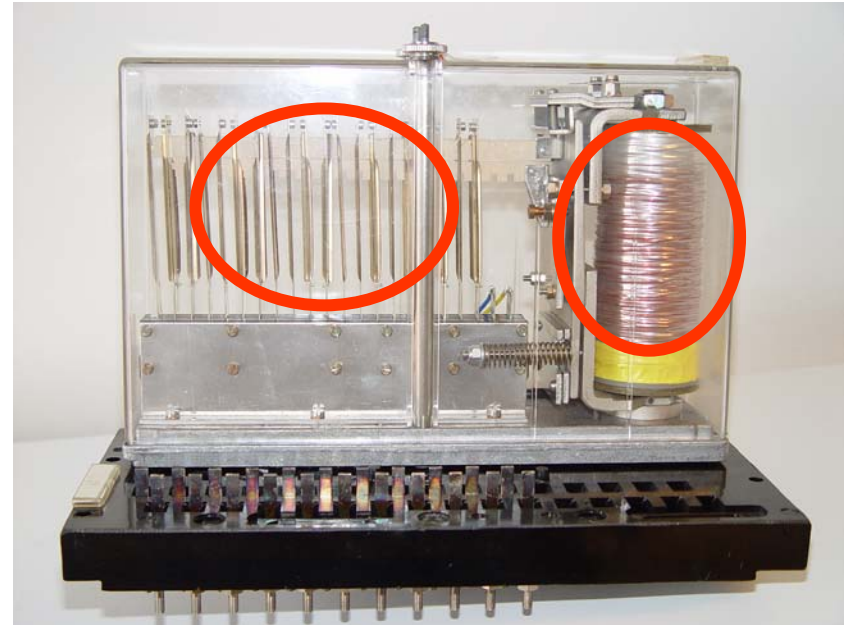

Relay Unit

# Track Circuits – Failure Modes for the rectifier unit

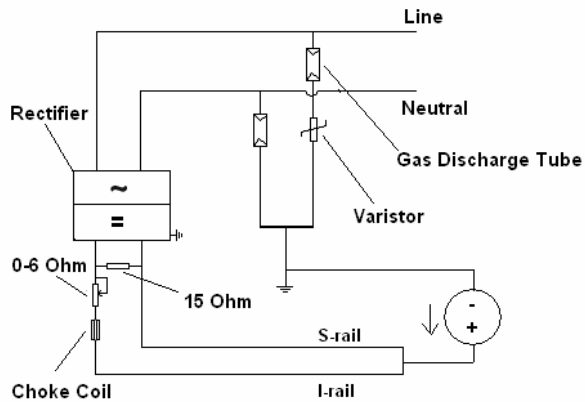

a). Common mode from track side

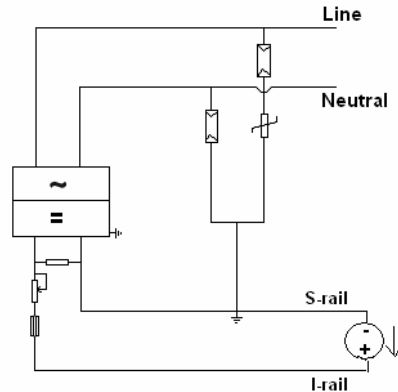

b). Differential mode from track side

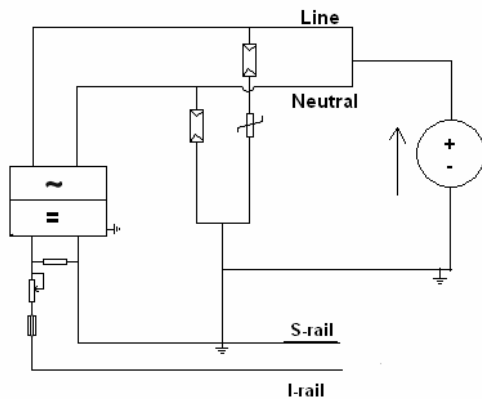

c). Common mode from power side

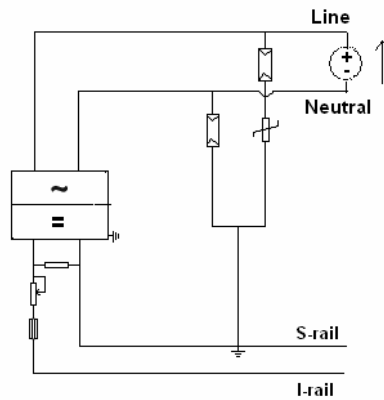

d). Differential mode from power side

- Common mode and differential mode tests are conducted with the voltage/current injection from the auxiliary power side or from the track side.
- Tests were made using an impulse generator in the laboratory.
- For the fourth case (d) that is differential mode injection from the auxiliary power side the diodes failed at about 3kV and a breakdown on the capacitor was also observed.



# Telecommunication Cable and Booster transformer

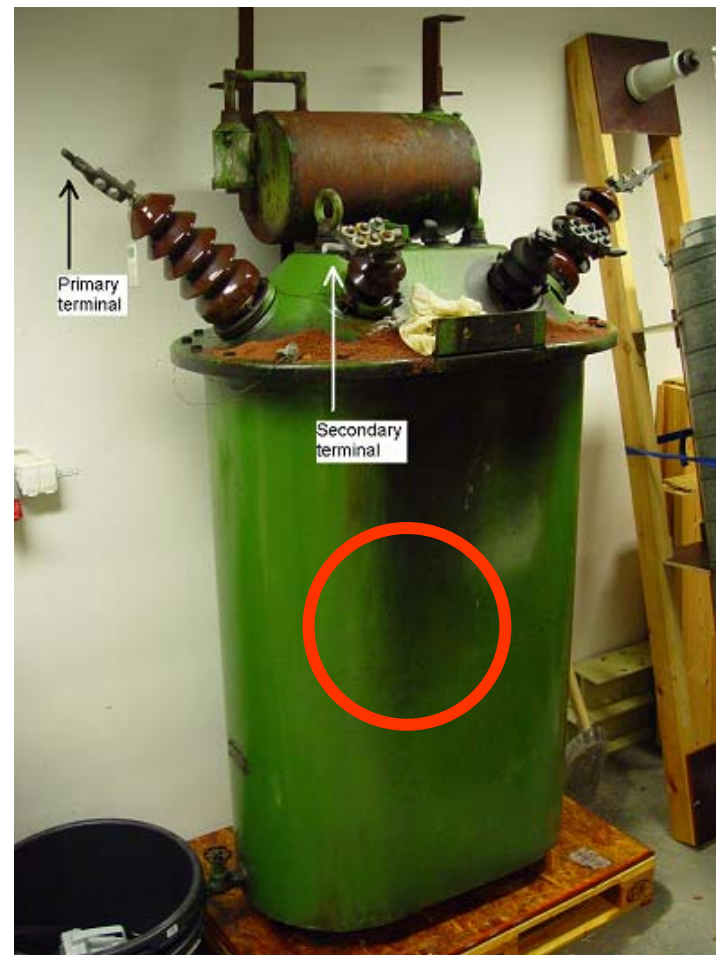

# Ground losses in Pulse Propagation System – Direct Strike

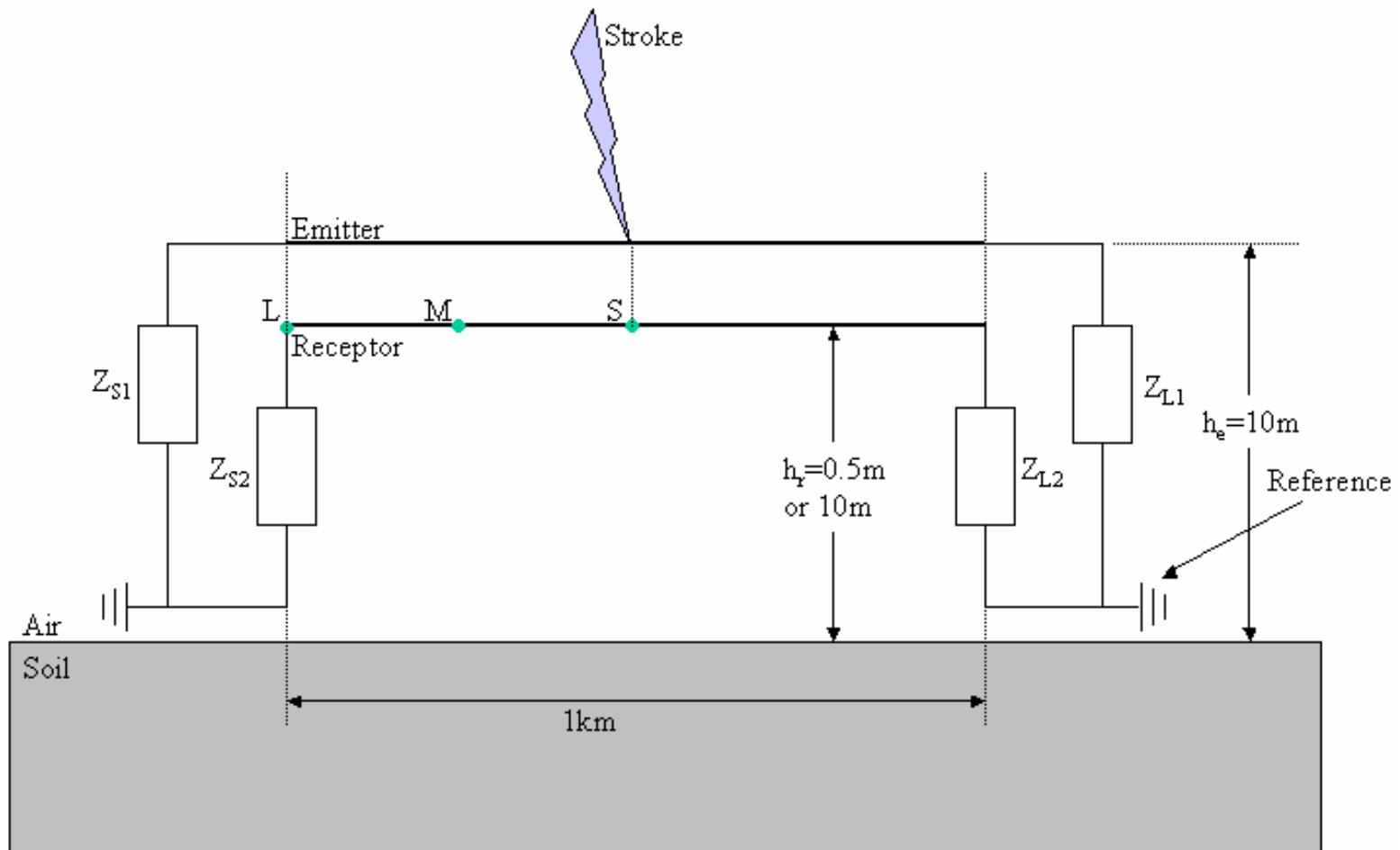

# Ground losses in Pulse Propagation Simulations – Direct Strike

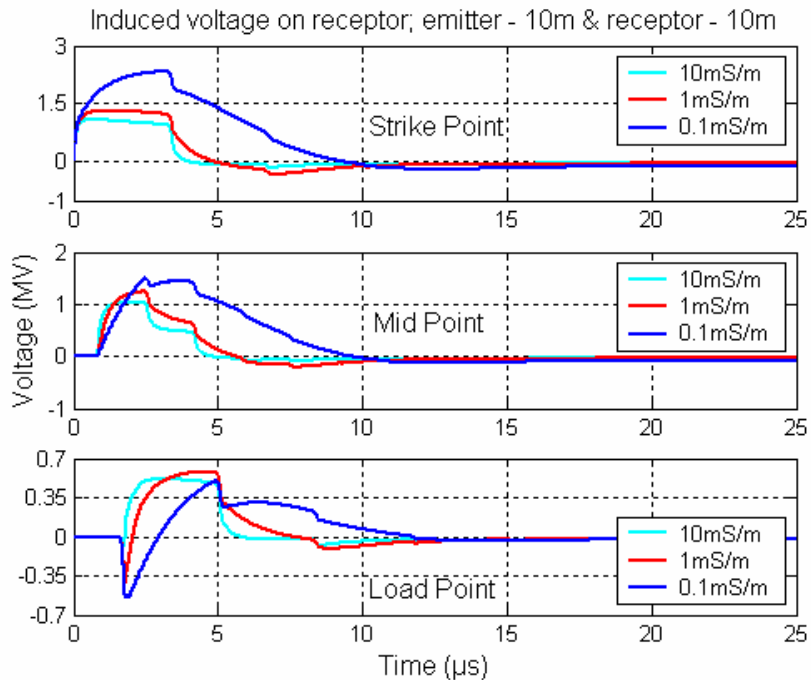

Conductor height 10m

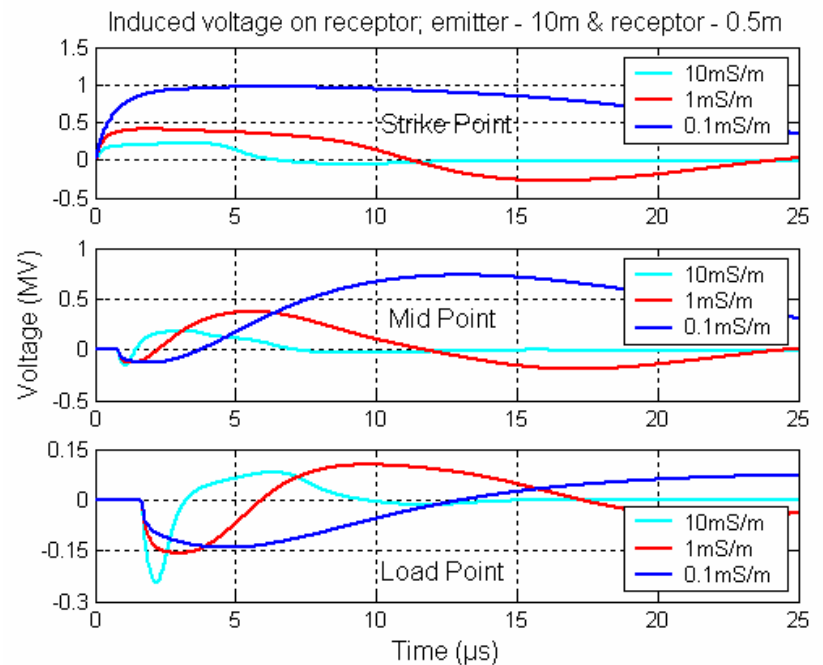

Conductor height 0.5m

# Pulse Propagation in Buried Wires – System and TL representation

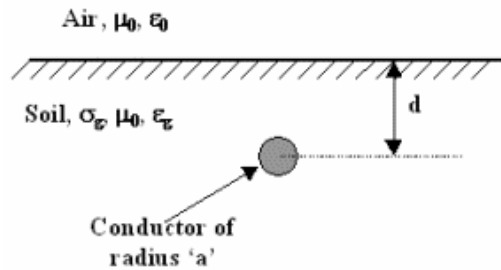

Bare Conductor

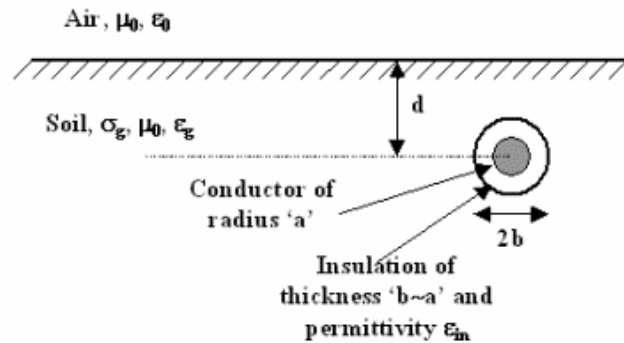

Insulated Conductor

Ground Impedance

Ground Admittance

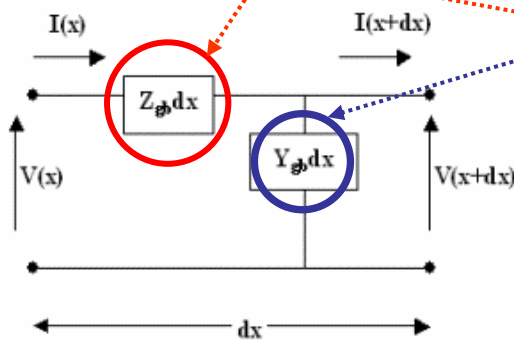

Bare Conductor

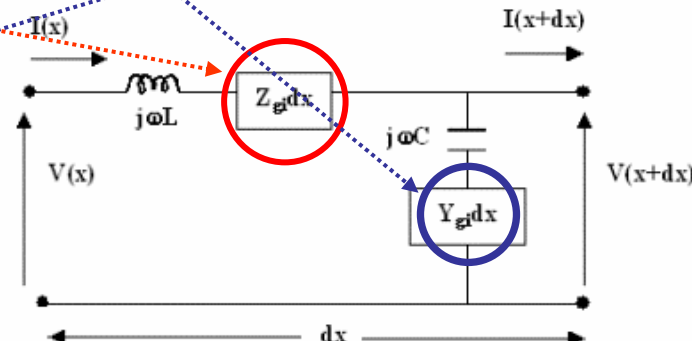

Insulated Conductor

$$L = \frac{\mu_0}{2 \cdot \pi} \ln\left(\frac{b}{a}\right)$$

$$C = \frac{2 \cdot \pi \cdot \epsilon_{in}}{\ln\left(\frac{b}{a}\right)}$$

# Propagation Characteristics are different for buried, bare and insulated Wires

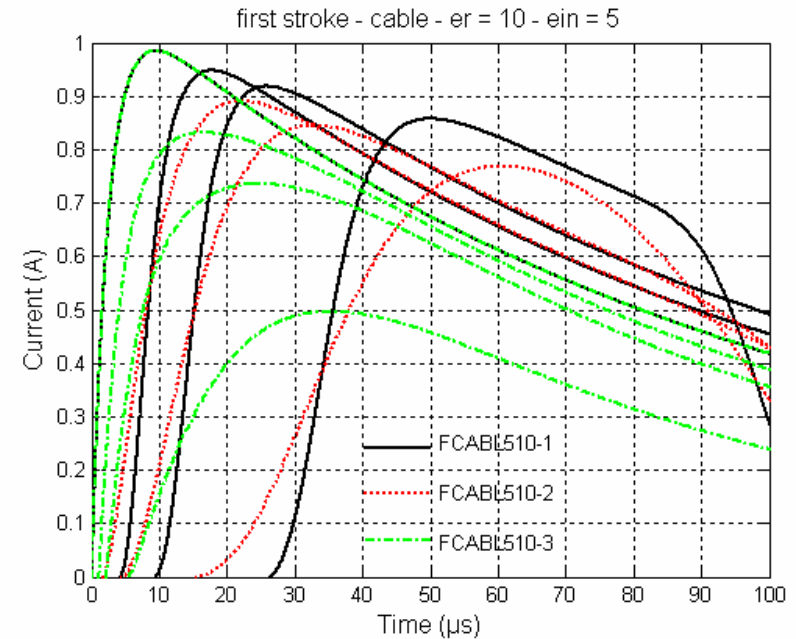
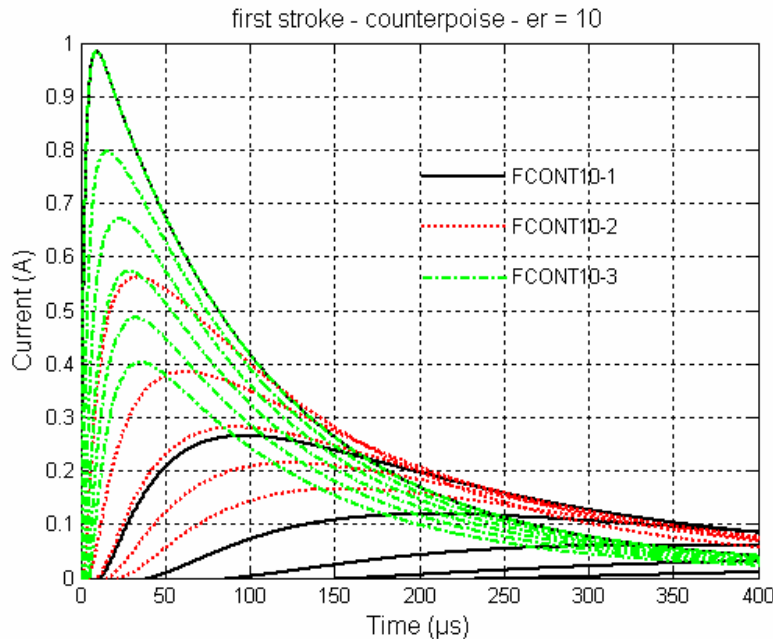

Wire length = 1km, burial depth 0.5m,

FCONT10-1, FCABL510-1  $\rightarrow \sigma_g = 10\text{mS/m}$ ,  $\epsilon_{rg} = 10$  and  $\epsilon_{ri} = 5$

FCONT10-2, FCABL510-2  $\rightarrow \sigma_g = 1\text{mS/m}$ ,  $\epsilon_{rg} = 10$  and  $\epsilon_{ri} = 5$

FCONT10-3, FCABL510-3  $\rightarrow \sigma_g = 0.1\text{mS/m}$ ,  $\epsilon_{rg} = 10$  and  $\epsilon_{ri} = 5$

Injected current at one end has  $10\mu\text{s}$  rise time and the other end is open. Currents are calculated at injection point and every 100m until 500m from injection point. Left figure bare wire and right figure insulated wire.

# Booster transformer modeling - 1

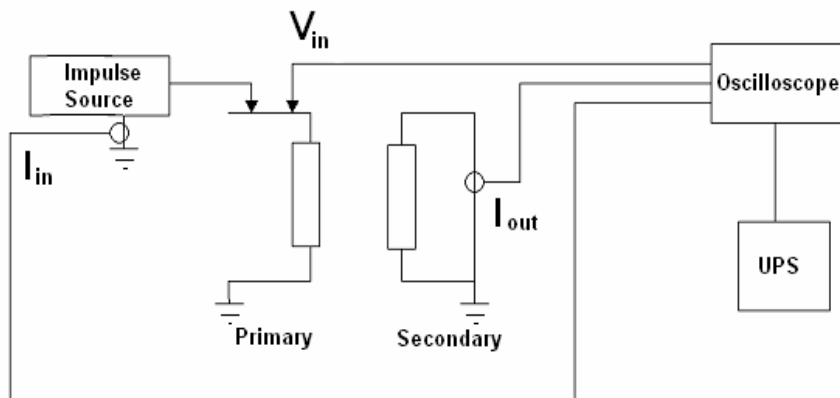
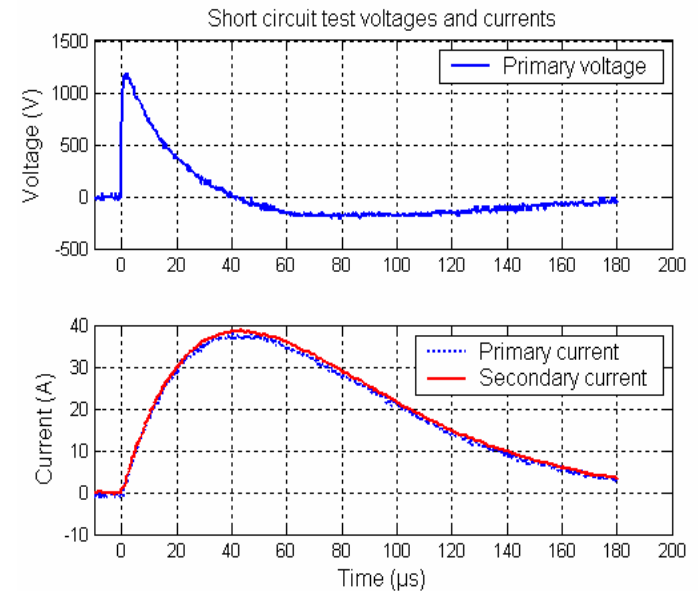
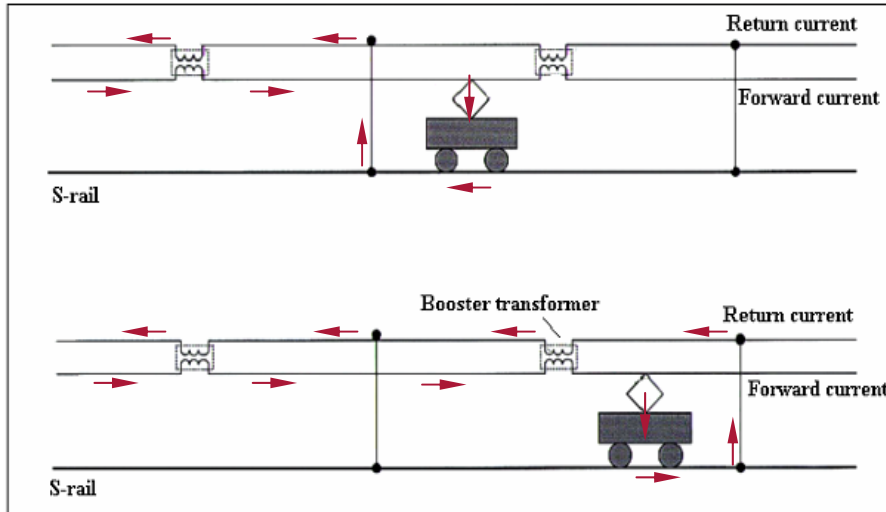

Short circuit tests are carried out for deriving the circuit model

# Lightning Transients Entering Technical House – Summer 2003

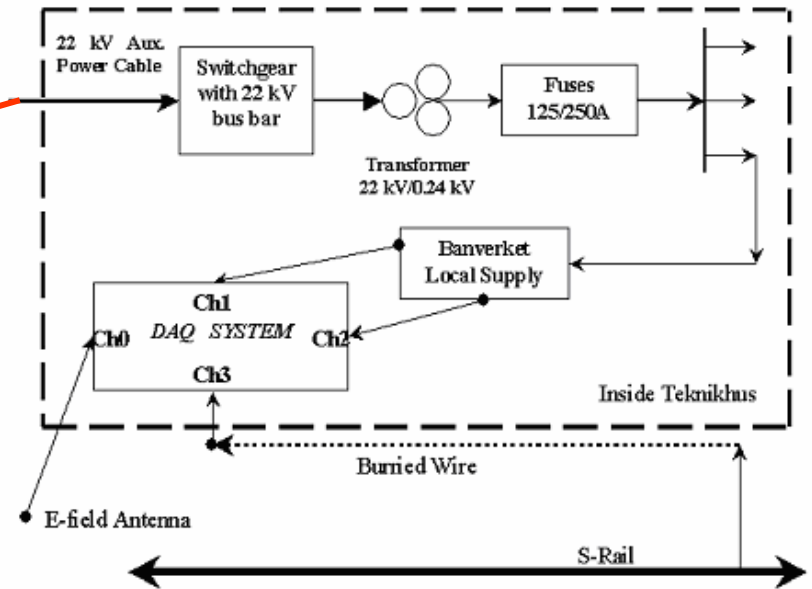
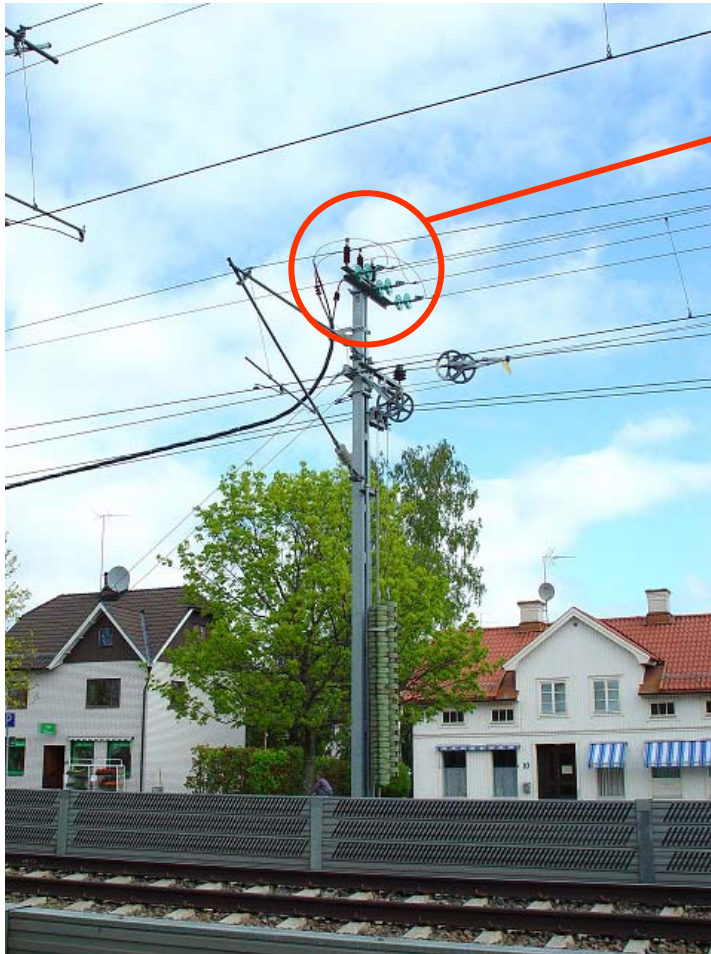

- Ch0 – Electric Field from lightning
- Ch1 – Line to neutral voltage
- Ch2 – Phase current
- Ch3 – S-rail to local ground current

# Typical measured transients

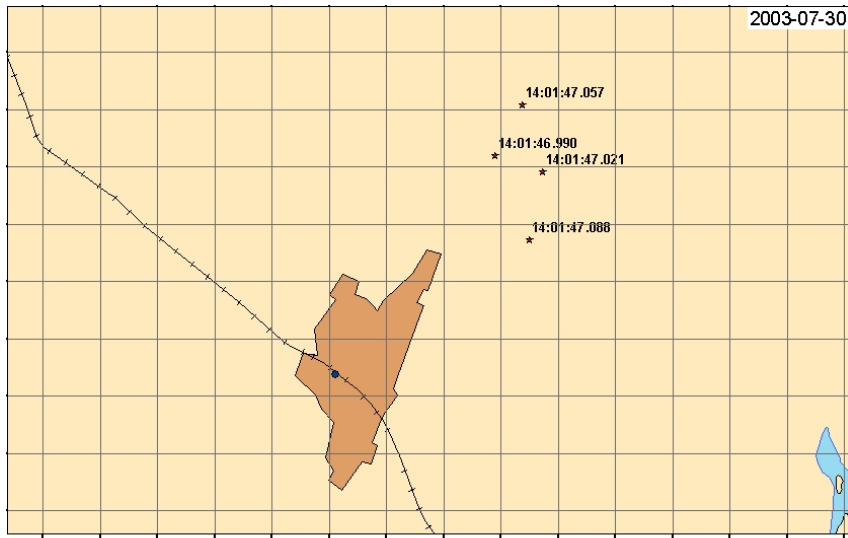

FID	Shape	DAG	TID	LAT	LON	AMP	Actual current
191857	Point	20030730	14:01:46.990	60.3803	17.5627	-170.4	-31,5
191858	Point	20030730	14:01:47.021	60.3775	17.5776	-104.5	-19,3
191859	Point	20030730	14:01:47.057	60.3881	17.5718	57	-10,5
191860	Point	20030730	14:01:47.088	60.367	17.5726	57,3	-10,6

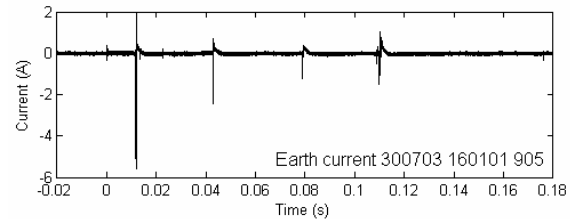
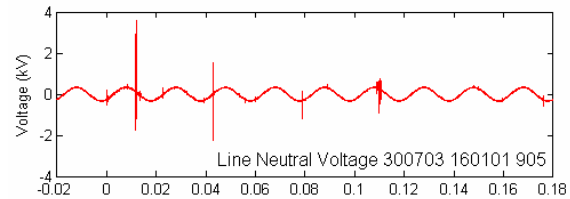
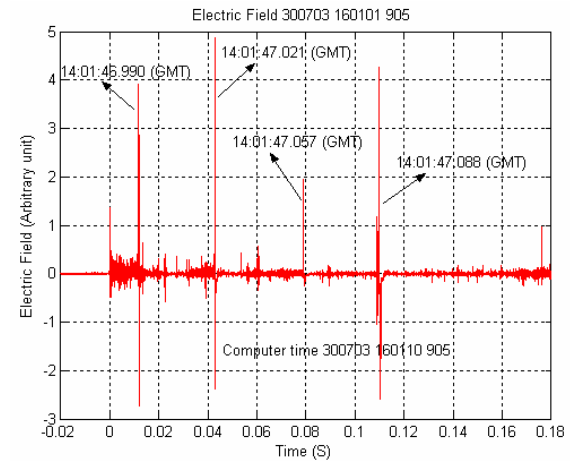

# Typical measured transients – First Stroke

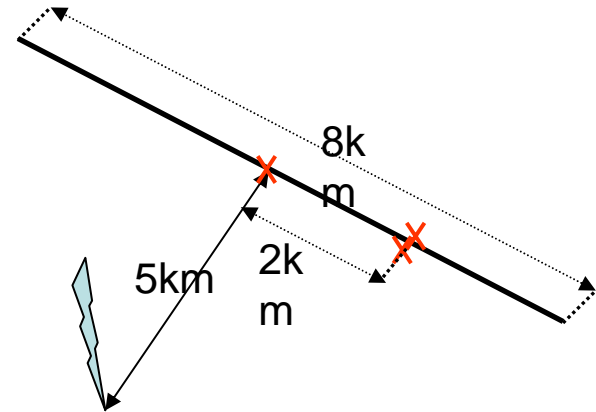

Stroke Current 31.5 kA [TL model]  
 $\sigma_g = \infty, 10\text{mS/m}, 1\text{mS/m}, 0.1\text{mS/m}$   
 Terminations: surge impedance  
 Line height: 10m: Auxiliary Power Wire  
 0.5m: S-Rail

Voltage at the input of the transformer with respect to neutral

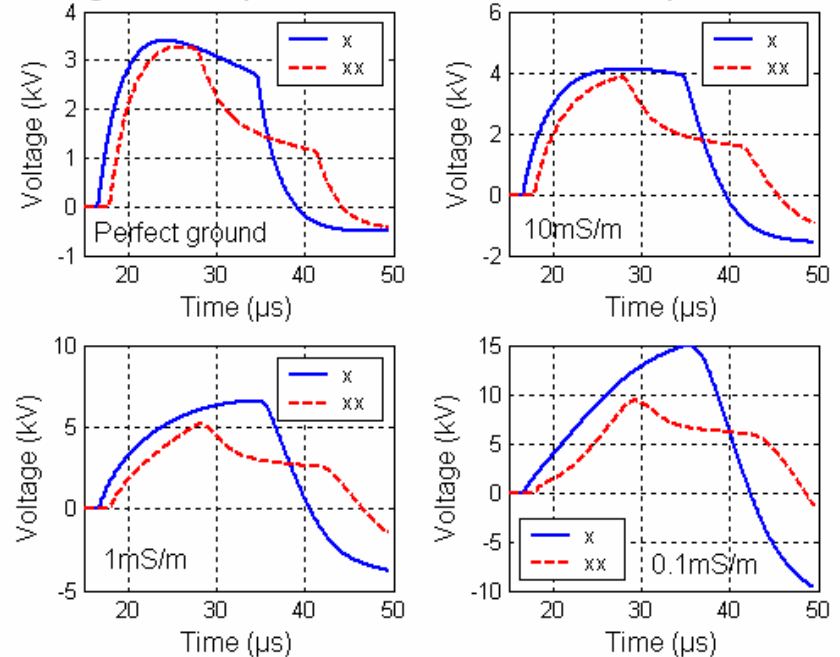

$$V_{\text{INDUCED}} = \frac{60 \cdot I_{\text{max}} \cdot h}{D}$$

$h$  = Line height (m)

$I_{\text{max}}$  = Peak Stroke Current (A)

$D$  = Distance from stroke to measuring point (m).

$$V_{\text{LN}} = \frac{C_v \cdot I_{\text{max}}}{D}$$

$C_v = 250 - 750$

$I_{\text{max}}$  = Peak Stroke Current (A)

$D$  = Distance from stroke to measuring point (m).

# What to do with unused pairs in telecommunication cable?

Comparison between the simulation and experiment for internal voltages

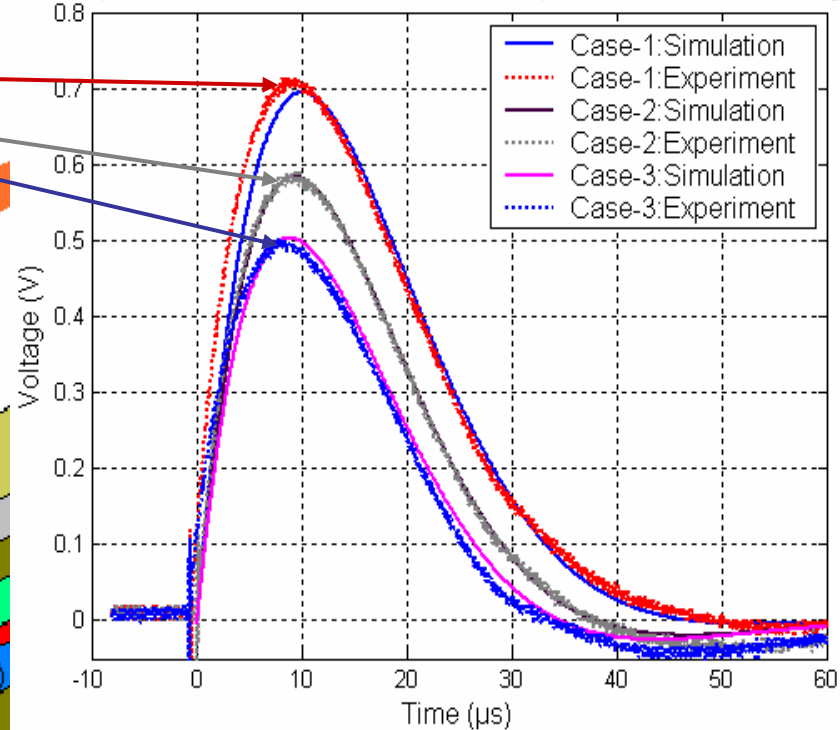

Case-3

Outer Insulation

Inner Insulation

Triax tube

Shield

$V_{oc}$

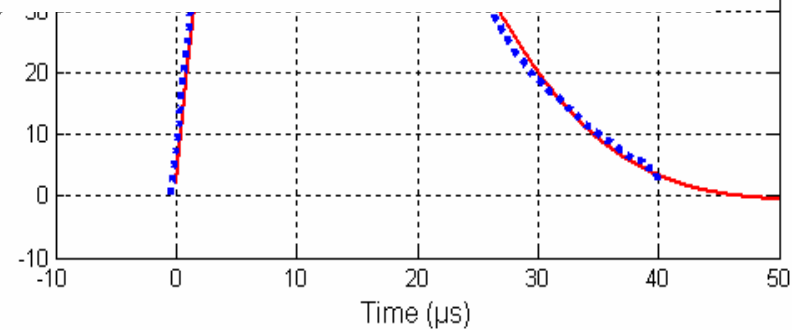

# Grounding system for Communication towers

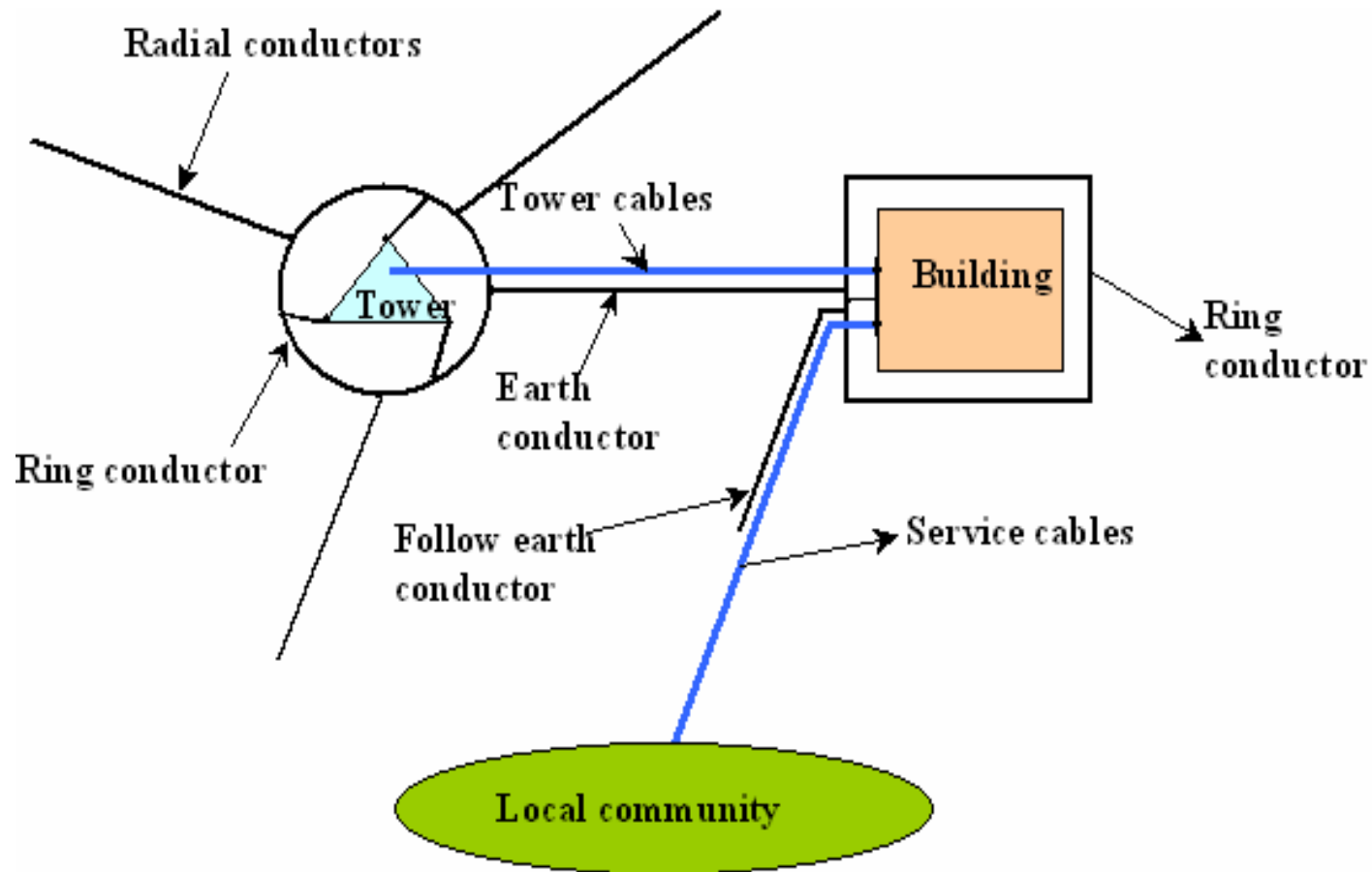

# Can follow on earth wire be used to reduced transients in Cable?

## Case-2

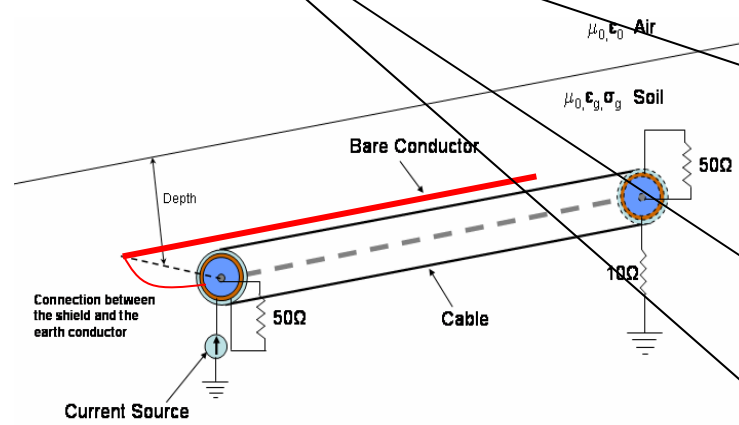

Potential difference between core and shield at 50m from injection point

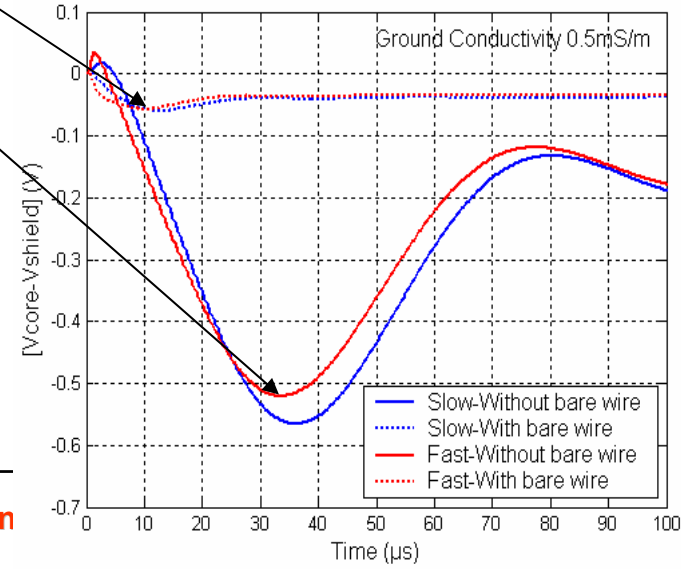
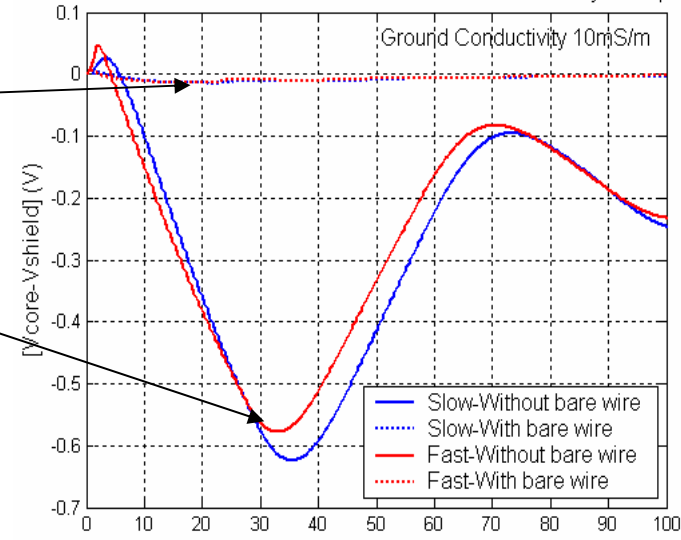

# Measurements: Gaisberg tower, Austria



# Current measurements



# Some preliminary measurement comparisons

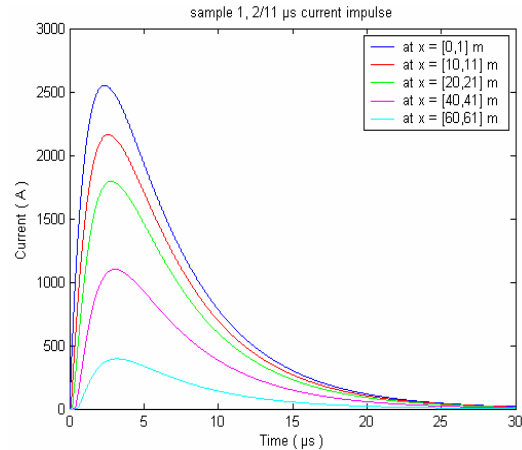

Flash #358, 2003-12-14; 10:22:28

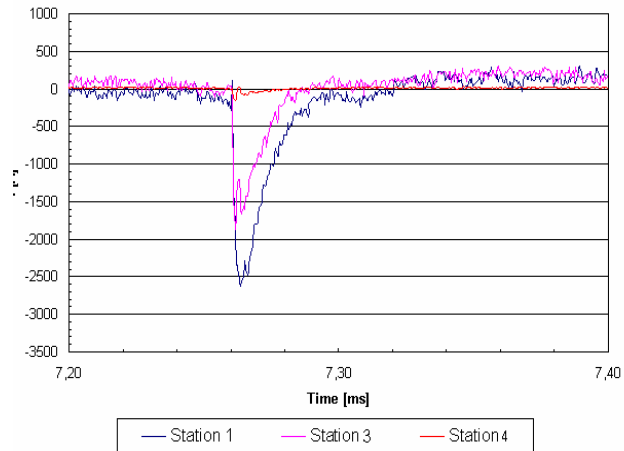

# Software for Lightning Interaction with Railway Systems

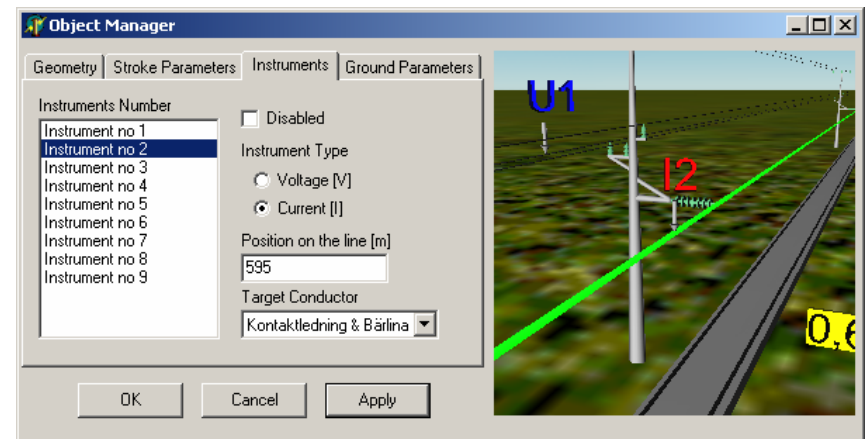
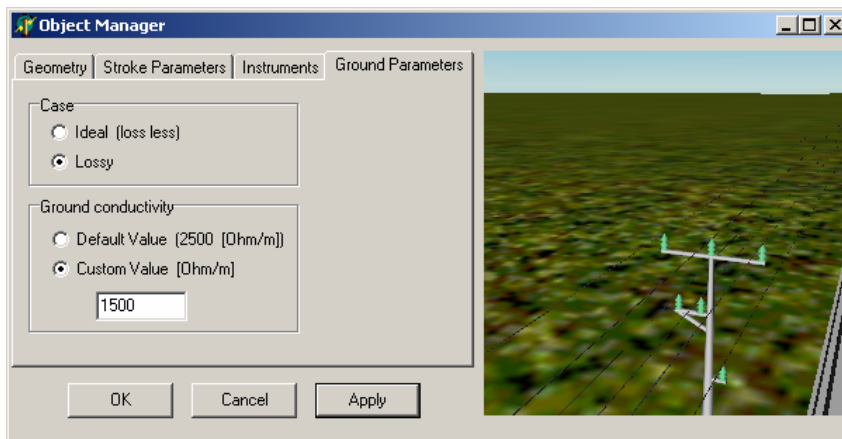
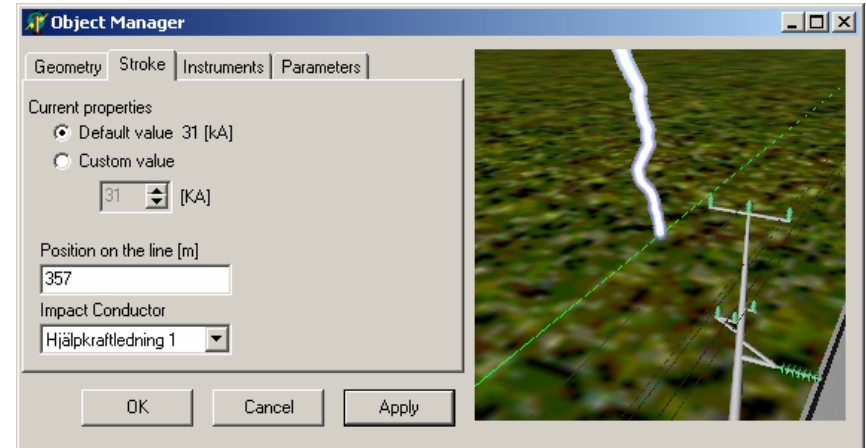
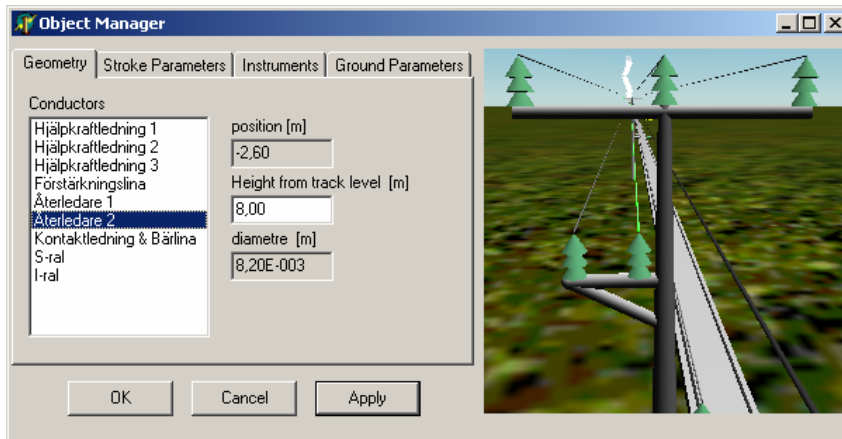

# Susceptibility of railway systems to Intentional EMI – EMC audits



# Future railway control and signal system

---

- ERTMS (European Rail Traffic Management System) level 2 and 3
- No optical signals (No green or red)
- Eurobalises for train positioning
- GSM-R communication to driver's cabin for signalling and control
- Possible effects of IEMI on eurobalises and GSM-R communication



# Pantograph Arcing: Model Geometry and issues

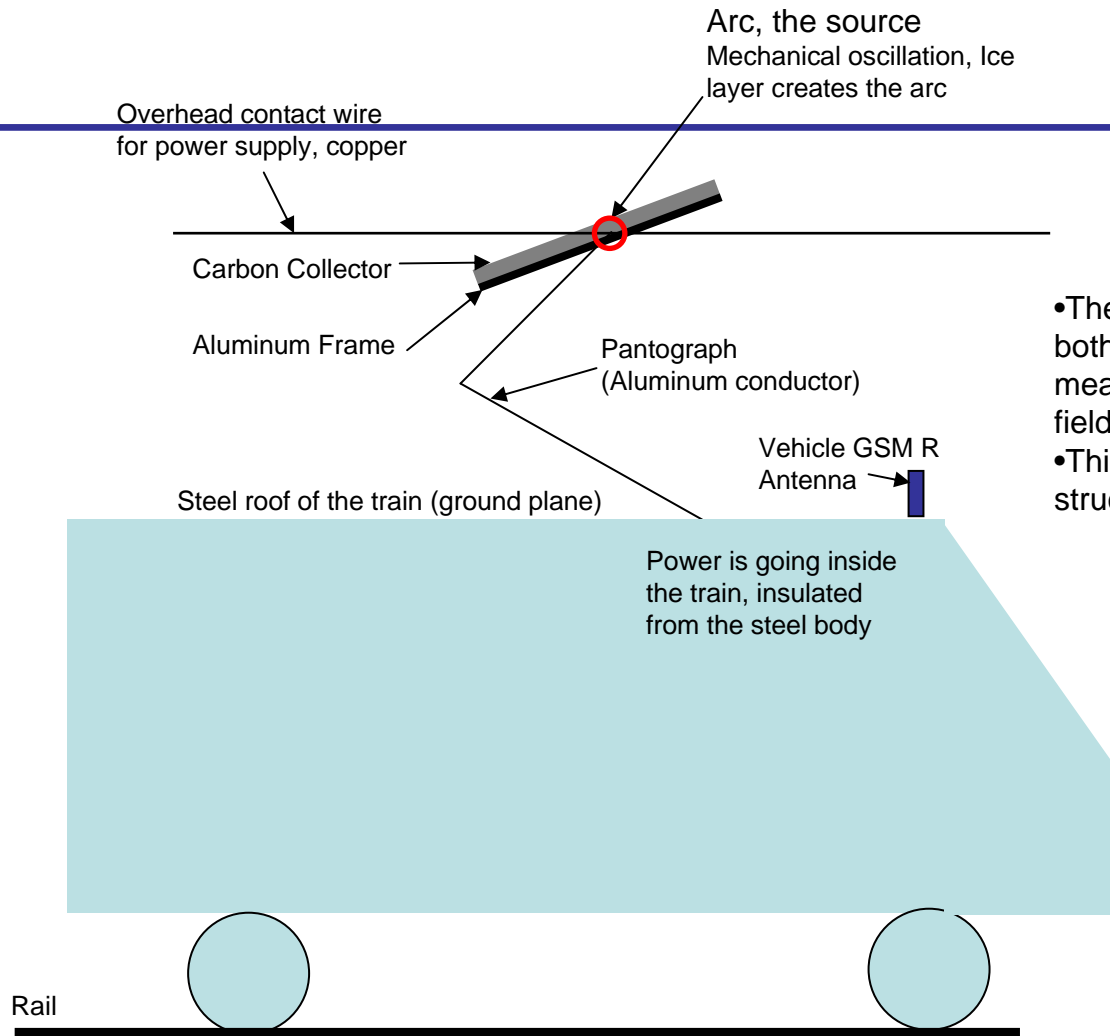

- The source will be characterized and modeled both theoretically and experimentally by measuring both the radiated field and conducted field
- This will be used as an excitation source to the structure

Radiation in the few hundreds of MHz to GHz is of interest, which can have interference in the railway communication and signaling

# Experimental Setup

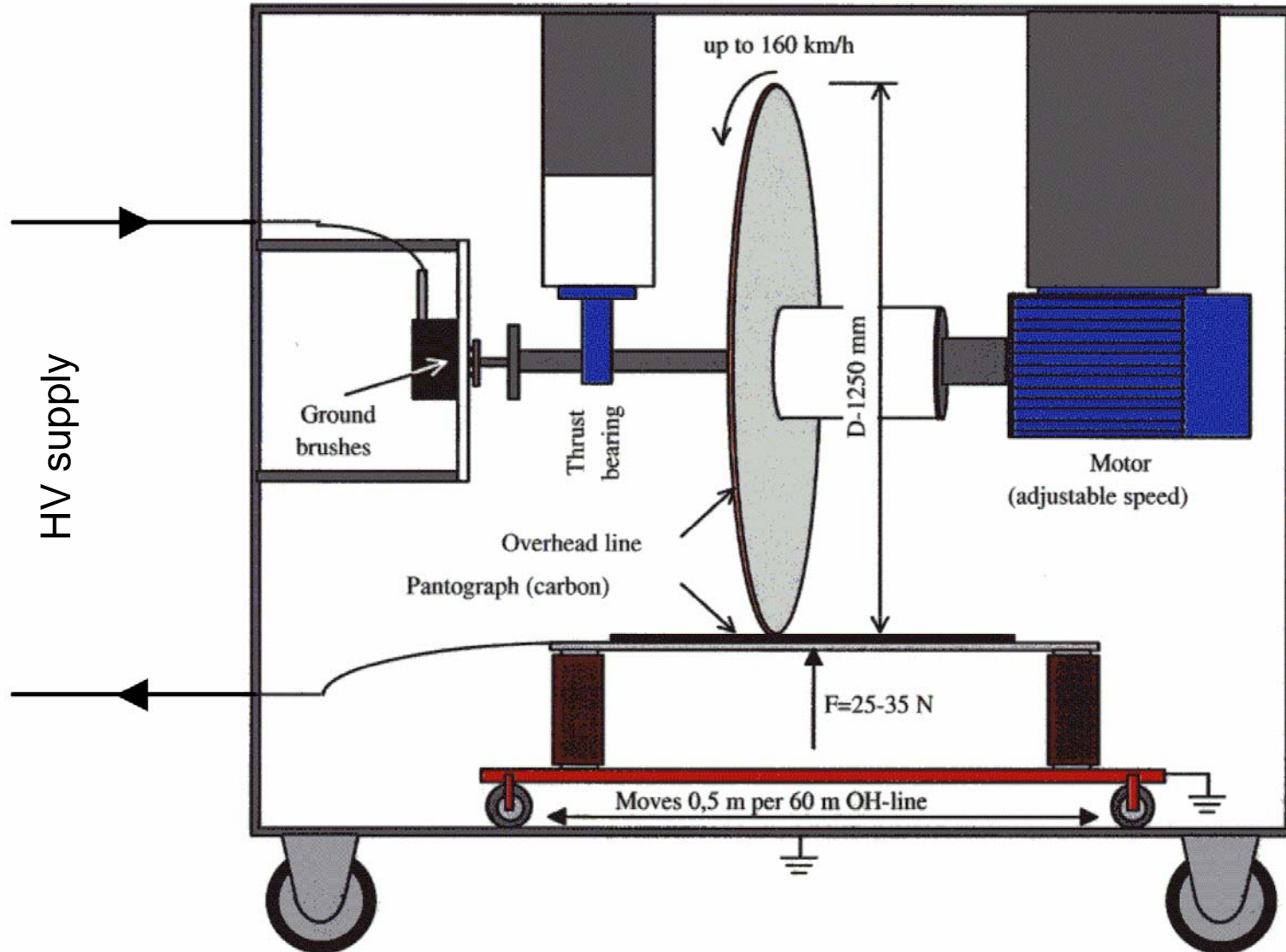

# Interference to the Balise from the Drives System

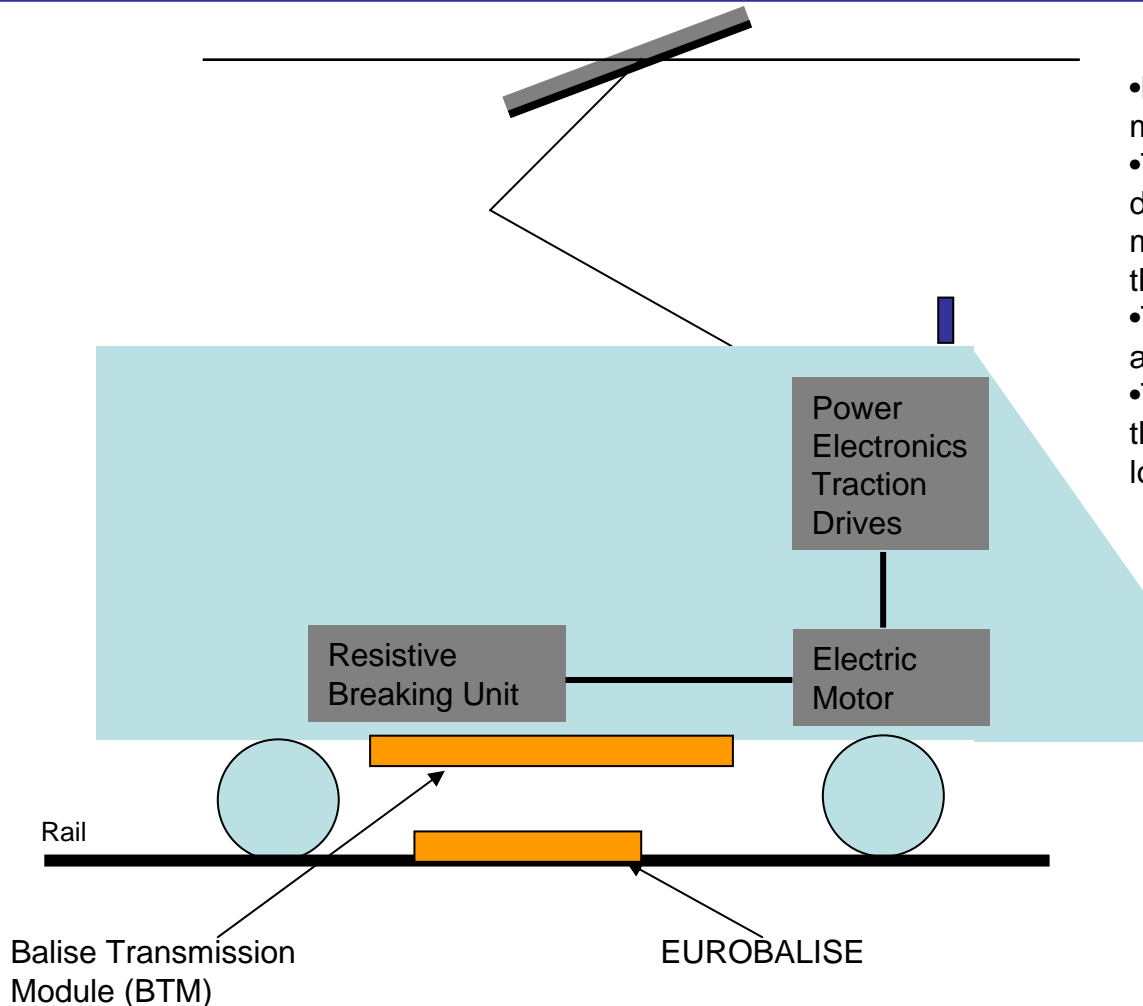

## Problem Overview

- Modern Drives System generates more and more fast switching
- The electrical connection path from drives/converter system to the motor and from motor to the electrical breaking system carry these sharp pulses
- These conducting path acts as a radiating antenna
- These sharp pulses generates interference with the Balise system and often creates information loss

## Information Required

- Exact location of the Drives/Converters, Motors and the Breaking Unit inside the cab for some trains (kind of electrical mapping)
- Type of cable used for these connections
- What type of Shielding methodology is presently being followed
- Type of the Drives/Converter system
- Availability of existing models