



ELVIS

Electromagnetic Vector Information Sensor

Jan E. S. Bergman¹

L. Åhlén¹, O. Stål¹, B. Thidé^{1,2}, S. Ananthakrishnan⁴,
J.-E. Wahlund¹, R. L. Karlsson¹, W. Puccio¹,
T. D. Carozzi³ and P. Kale⁵

¹Swedish Institute of Space Physics, Uppsåla, Sweden

²LOIS Space Centre, Växjö, Sweden

³Space Science Centre, Sussex University, Brighton, UK

⁴National Centre for Radio Astrophysics,
Tata Institute of Fundamental Research
Pune University Campus, Ganeshkhind, Pune, India

⁵Integrated Circuit and Information Technology Pvt. Ltd.
Department of Electronic Science,
University of Pune, Ganeshkhind, Pune, India

To Moon and Beyond,
Bremen, Germany, September 15 – 16, 2005



Outline

- ELVIS
 - Broad Specification
 - Scientific Objectives
- Electromagnetic Environment
 - Lunar Plasma
 - Radio observations on the Moon
 - Ultra-high energy neutrino detection
- Operation
 - Polarization in 3D
 - Signal processing
 - Modes of operation
- Summary
 - Design philosophy
 - Relation to other projects

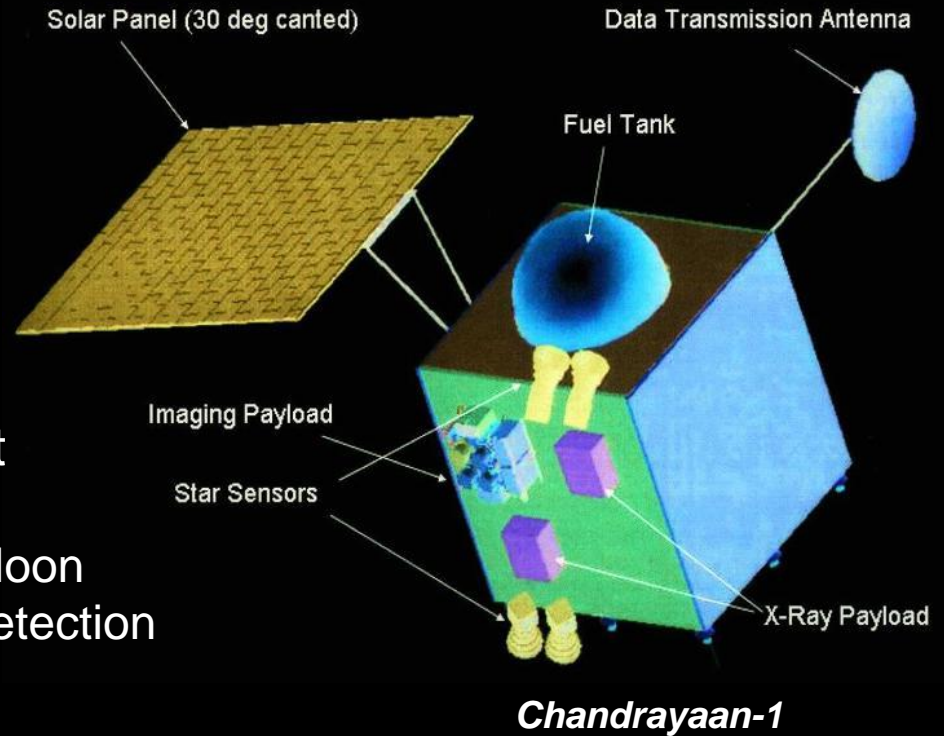



Broad Specification

- E-field vector up to 18 MHz
 - Three orthogonal 5 m dipole antennas
- Magnetic field up to 100 kHz
 - One component search coil sensor
- Four ADC's: 14 bit@40 Msp
- 4-channel digital downconverter (DDC)
- Bandwidths between 5 kHz and 20 MHz
 - Dynamic range:
 - 84 dB@20 MHz – 120 dB@5 kHz
- Sensitivity: -135 dBm/Hz
- Transient detection up to 200 MHz
 - 14 bit@80 Msp
 - Nyquist filter bypassed
- Mass: 1680 gram (830g with 2m dipoles)
- Power: Nominal 4W (Peak 7W)
- Telemetry: Max 128 kbps
- Total cost: 300 kEURO

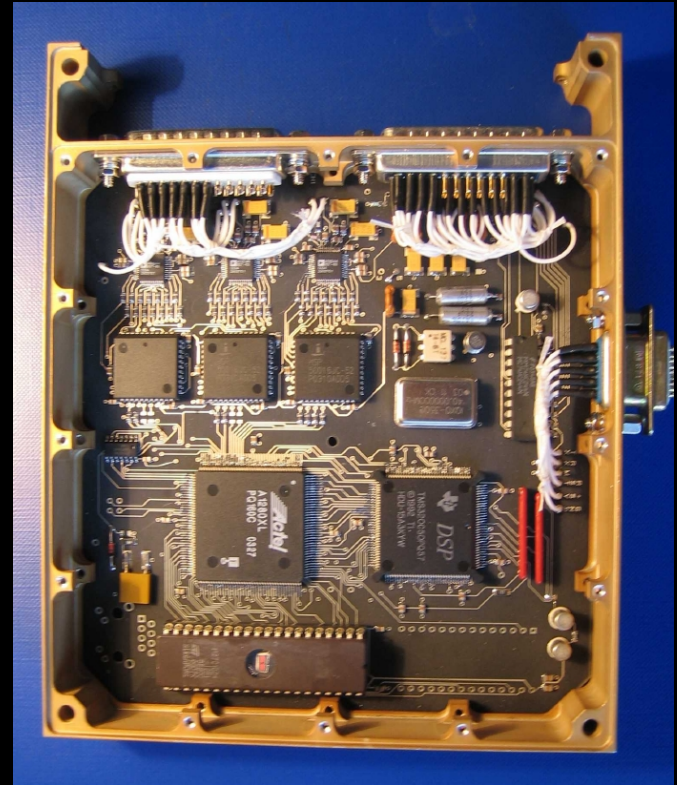

*Vector receiver module.
Installation on ISS in 2007.*



ELVIS Block Diagram

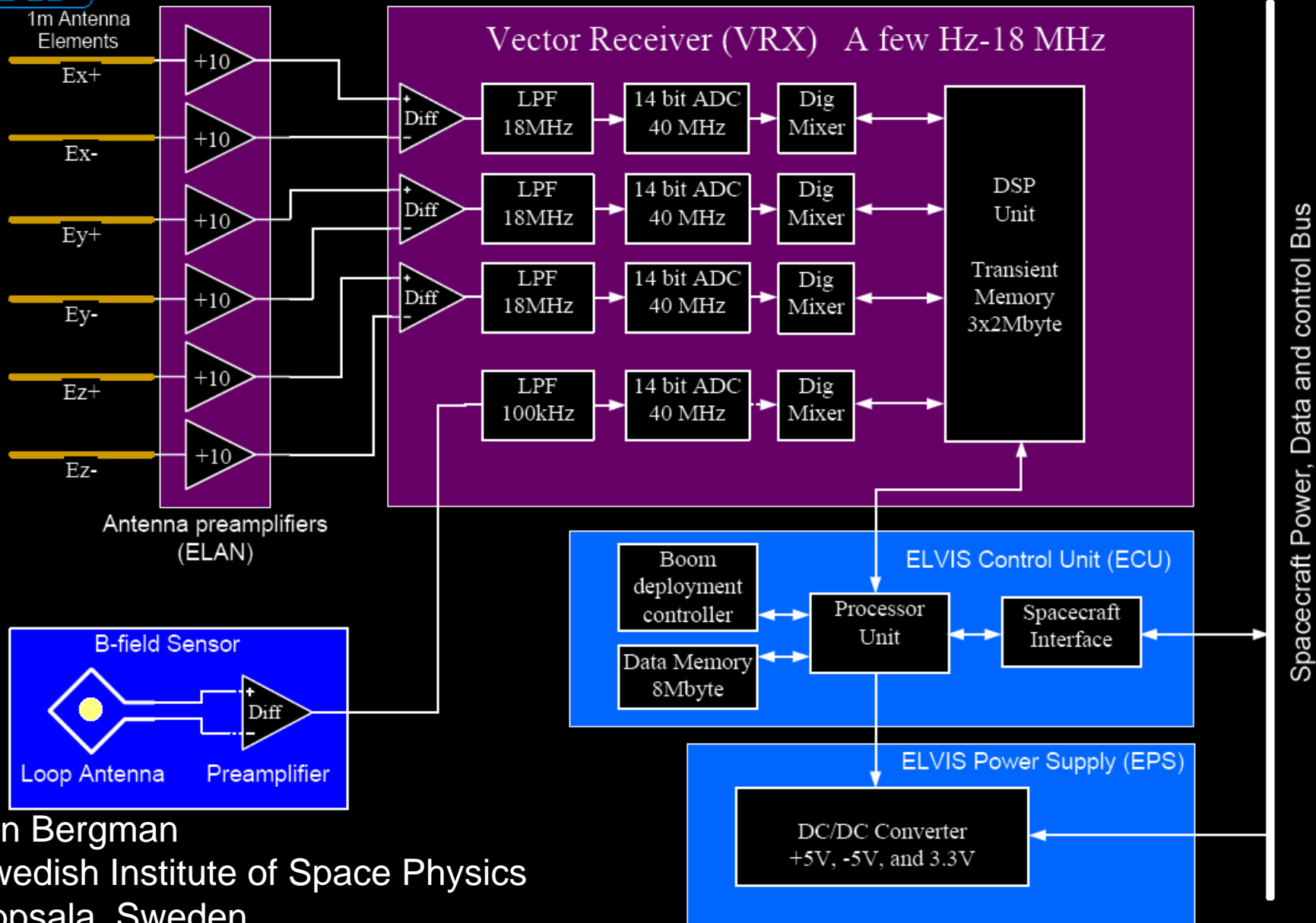

Jan Bergman
Swedish Institute of Space Physics
Uppsala, Sweden



Scientific Objectives

- Exploration of the EM environment of the Moon
 - Properties
 - Sources
 - Origins
- Study the Moon in *itself*
- Use the Moon as a *shield*
- Use the Moon as a *target*



- Whole range of unexplored plasma phenomena
- WIND lunar wake crossing at $6.8 R_L$
 - Electron density as low as 0.01 cm^{-3}
 - Lunar wake cross current
 - Filled with radio waves
- Lunar ionosphere
 - Luna 22: Electron density of 2000 cm^{-3}
- Interaction with the geomagnetic tail
 - Mass loading?
 - Diversion of magnetospheric currents?
- Lunar mini-magnetospheres
 - Small-scale shocks and associated wave-particle interactions

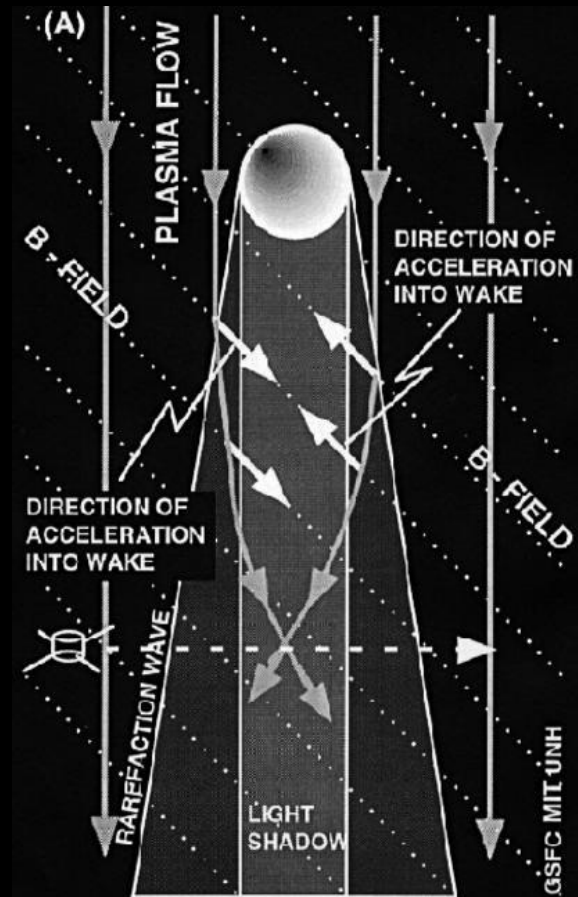

*Lunar wake dynamics
cartooned from WIND
measurements*



Radio observations on the Moon

shield

- Low-frequency radio telescope on the Moon
 - Phased array with lightweight tripole antennas
 - Pioneered in Europe by LOFAR and LOIS
- ELVIS demonstrates the performance of one such antenna on a precursory mission
- Better knowledge of the EM environment required before a low-frequency radio observatory on the Moon can be realized
- Coordinated measurements with ELVIS and LOFAR/LOIS would produce significant science



LOIS tripole array in Växjö, Sweden



Ultra-high energy neutrino detection

- Radio methods can be used to detect neutrino induced radio pulses emanating from the Moon [Askar'yan 1962]
 - GLUE collaboration (1999 – 2003, no events detected)
 - ANITA (2006-2007), NASA balloon mission over Antarctica
 - Recently also LOFAR [O. Scholten et.al., Aug. 2005]
- ELVIS could detect these radio emissions in Moon orbit
 - SNR increased 70 dB compared to observations from Earth!
 - No losses due to polarization mismatch
 - Simulations show probability of 2.2 events per year
- A dedicated neutrino detection mission could increase this detection probability by several factors of 10!

target



© Goldstone/NASA

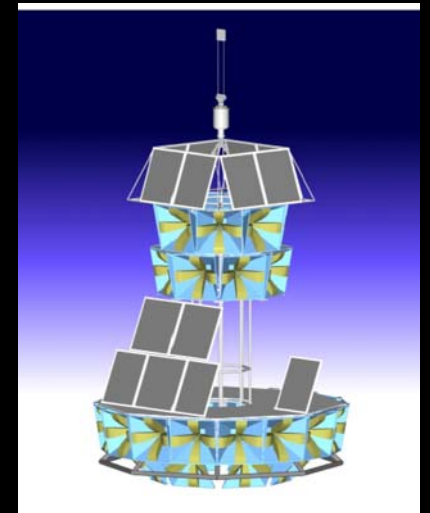

© ANITA Collaboration

Jan Bergman
Swedish Institute of Space Physics
Uppsala, Sweden

To Moon and Beyond
Bremen, Germany
September 15 – 16, 2005

Polarization in 3D

- Complex vector field: $\mathbf{E}(\mathbf{x}, t)$
- Polarization: 2nd order statistics

$$\mathbf{S} = \mathbf{E}\mathbf{E}^\dagger = \begin{pmatrix} E_x E_x^* & E_x E_y^* & E_x E_z^* \\ E_y E_x^* & E_y E_y^* & E_y E_z^* \\ E_z E_x^* & E_z E_y^* & E_z E_z^* \end{pmatrix}$$

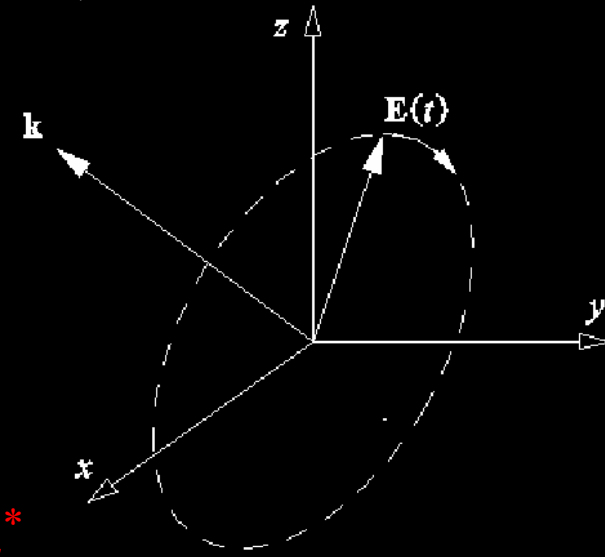

- Intensity is just the trace: $I = \mathbf{E} \cdot \mathbf{E}^*$
- Direction given by: $\mathbf{k} \propto i\mathbf{E} \times \mathbf{E}^*$
- Neutrino induced pulses are linearly polarized!



Signal Processing

- At 40 Msps, ELVIS produces 4 Gbps of data
- This huge data rate must be reduced
- Major reduction performed in DDC
 - Down to 1 Mbps at 5 kHz BW
 - Not enough!
- Post processing in DSP necessary
 - Trade-off between time, frequency and polarization coverage
 - Field entropy is calculated regularly and passed to HK
 - Entropy is a measure of information
 - Can be used to turn on special modes and as a signal for other instruments

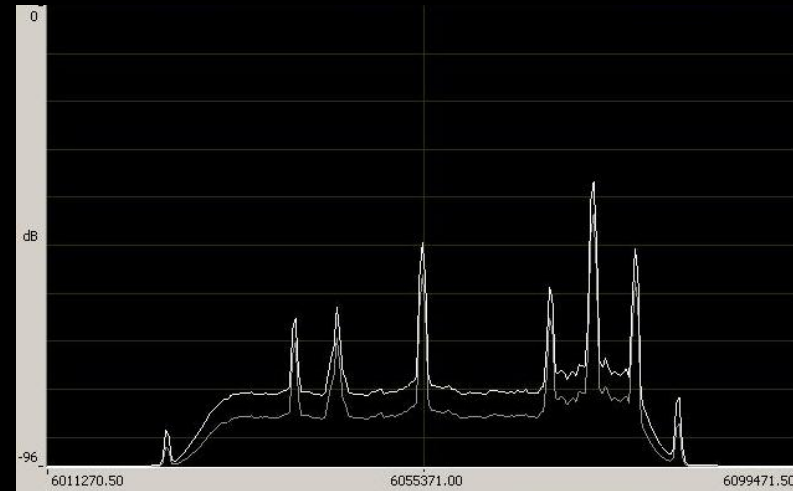

“Entropy”, P , (gray) and Intensity, I , (white) spectra captured by the LOIS receiver in Uppsala 2005-03-15 at 14:25 LT. Peaks are broadcast stations, where $P=I$. At the noise floor $P<I$.



Modes of Operation

- Survey mode (SM) 60%
 - Narrowband frequency sweeps
- Normal mode (NM) 15%
 - Baseband IQ receiver
- Burst mode (BM) 15%
 - Full bandwidth waveform capture
- Transient mode (TM) 10%
 - Sampling frequency doubled to 80 Msps
 - Nyquist filter bypassed
 - Only store events identified as transients





Design Philosophy

- Eliminate unnecessary analogue electronics
- Perform RX functionality in DDC and DSP
 - Minimized signal distortion
 - Reduced mass
 - Increased flexibility
- High-speed ADC's
- Quad DDC quadrature mixers and filters
- DSP for higher level signal processing

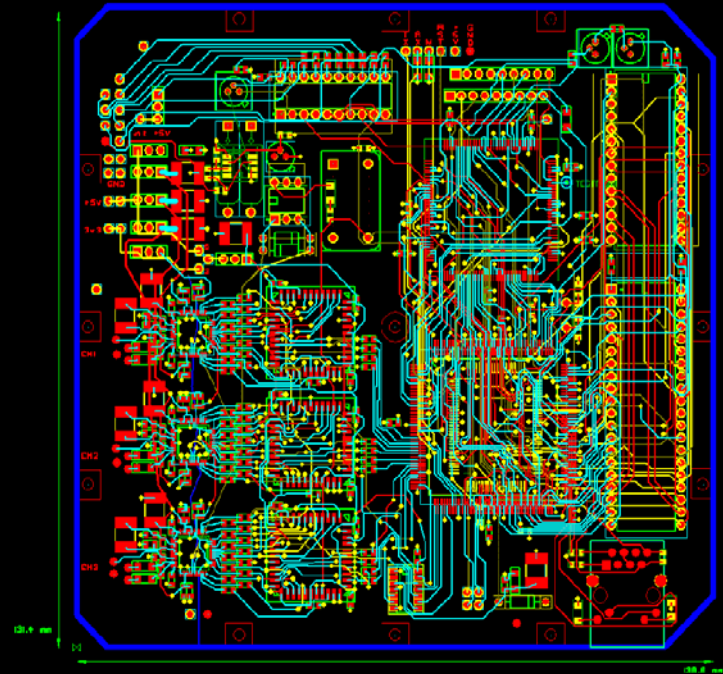



Relation to other projects

- Heritage from Cluster, Rosetta and Cassini
- NanoSpace-1 satellite (2007 – 2008)
 - Miniaturized ELVIS instrument MCM
- LOIS teststation (2004 – 2005)
 - LOFAR Outrigger In Scandinavia
- Compass-2 satellite (~~Today~~ October 2005)
 - Detection of precursors to earthquakes
- Obstanovka-1 for ISS (2006 – 2007)
 - Monitoring of ISS environment
- *One micro-satellite per year in the coming years*
 - *Russia, Taiwan, Mexico, ...*

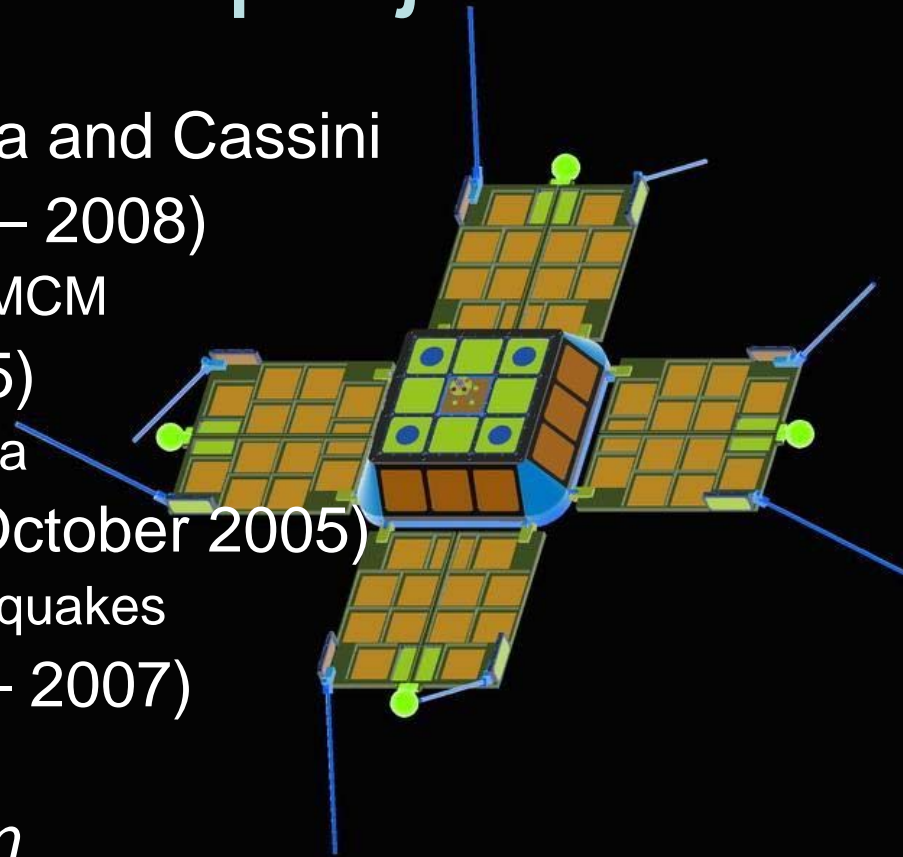

*The Moon over Uppsala
captured by W. Puccio*

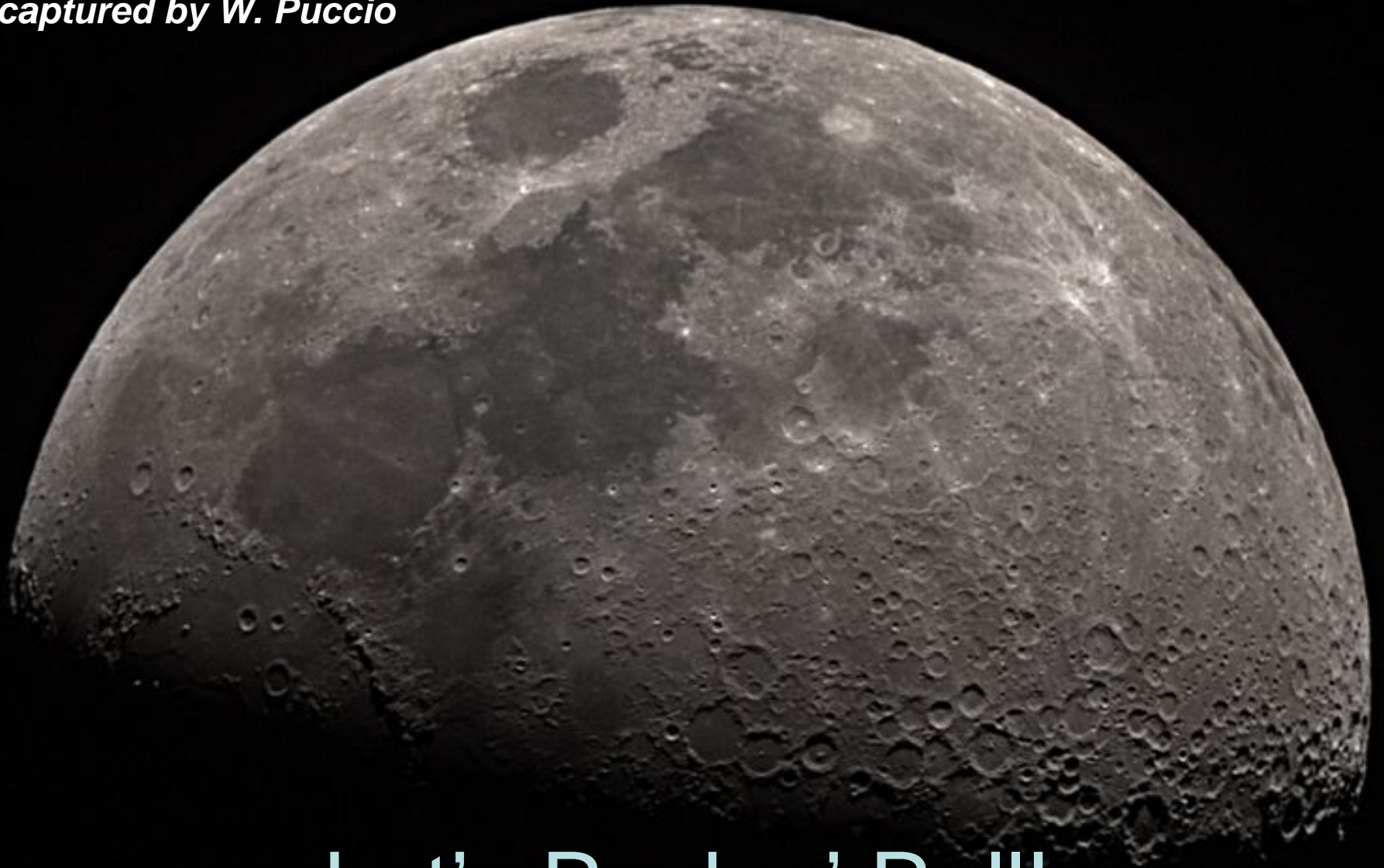

Let's Rock n' Roll!

Extra Slides



Electric Antennas (EANT)

- 6×2500 mm monopoles
- Metal foil on reel
 - Titanium, Be-bronze or stainless steel
- 150 gram per unit
- Well proven design
 - Alouette, Cassini, ...

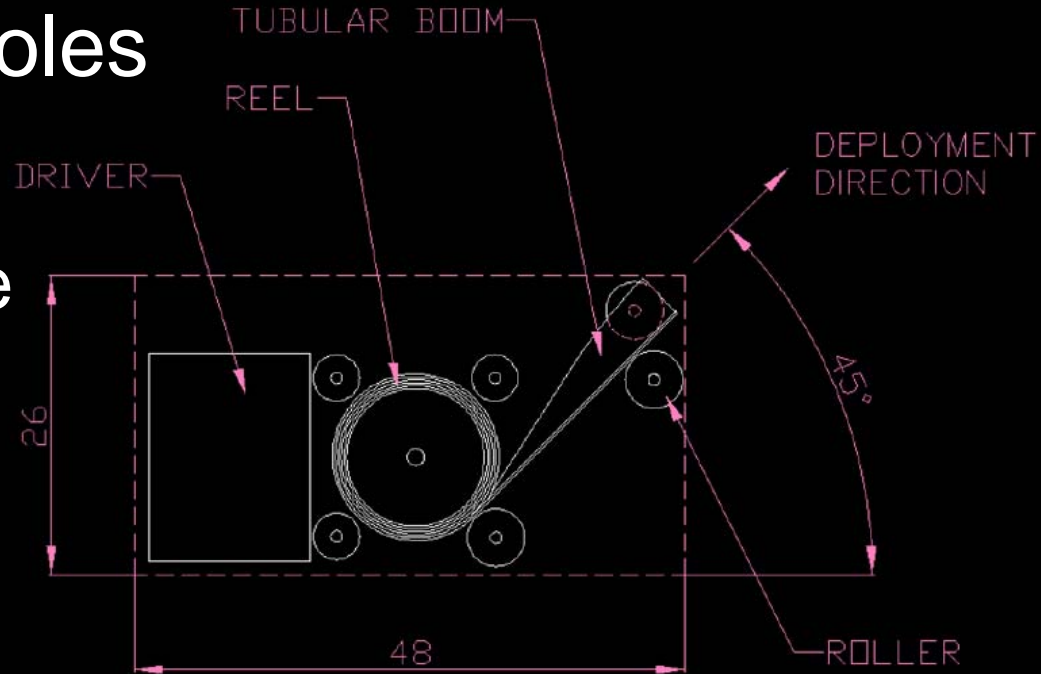

*EANT deployment unit,
NS1 25 g/1000 mm version.*



Search Coil Sensor (BANT)

- A few Hz up to 100 KHz
- Single high permeability core
 - 1000 windings
- Preamp feedback winding
 - Reduces coil resonance
- Open cylindrical case
 - Reduces E-field pickup
- Preamp close to sensor
 - Reduces harness noise
- Bellow-hinge boom
 - Minimum 500 mm
 - Low melting point metal release mechanism
- Total mass 150 gram

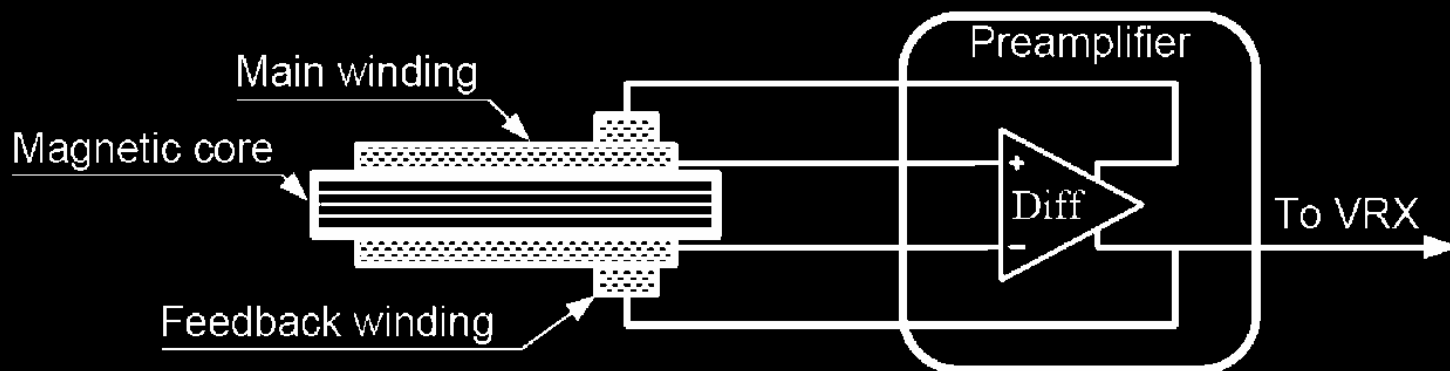



Electronics box (JUKEBOX)

- Two Al (Mg) frames
 - One VRX board
 - One EPS/ECU board
- Mass 630 (530) gram

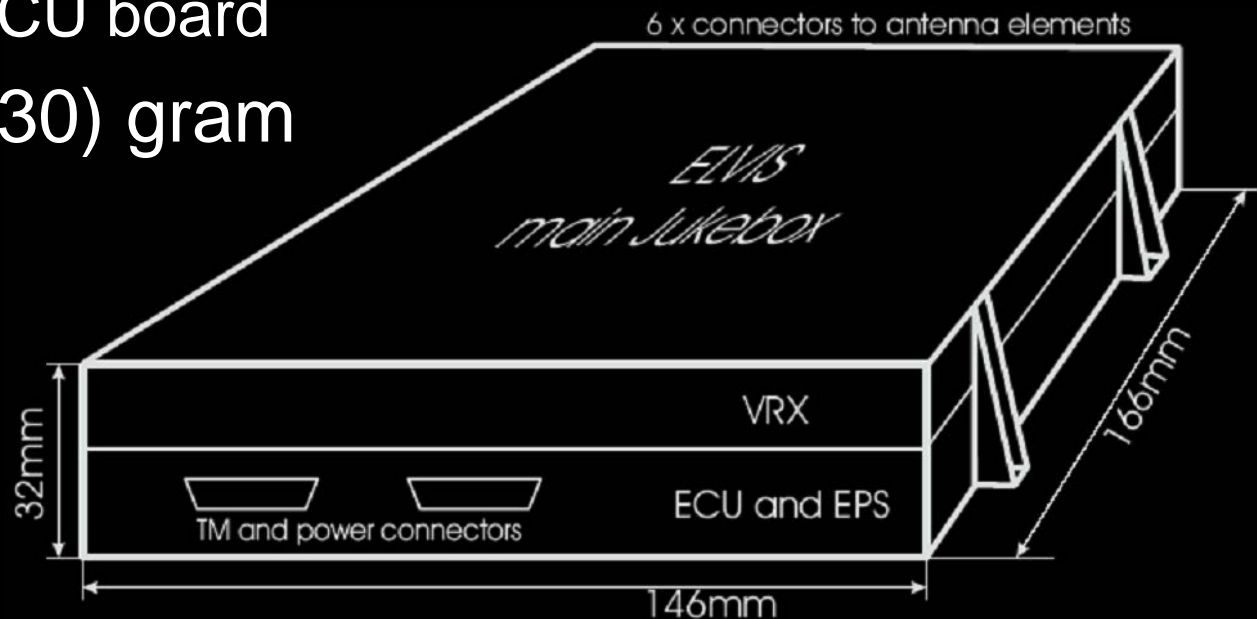



ELVIS Controller Unit (ECU)

- ECU processor
 - Atmel 8-bit processor
- 8 MB buffer memory
- S/C Interface for
 - Telemetry
 - Telecommands
 - Housekeeping (HK)
 - S/C Timing



ELVIS Power Supply (EPS)

- DC/DC converter
 - Single 28V S/C power interface
 - $\pm 5V$, 3.3V output voltages
- Nominal power: 4W
- Peak power: 7W
 - During transient detection



Power and Mass

| Mode | Measured Quantity | Power (mW) |
|-------------------|---------------------|------------|
| SM,NM | B/E (one component) | 1100/1240 |
| SM,NM | E (vector)+ B | 3780 |
| BM (during 25 ms) | E (vector) | 3780 |
| TM (@80 Msps) | E (vector) | 6300 |

| Unit | Mass (gram) |
|------------------------------------|------------------------------------|
| JUKEBOX, Main Electronics Box | 630 (Mg 530) |
| EANT, 6xElectric monopole elements | 6x150 (6x25 for 1000 mm elements)) |
| BANT Magnetic Antenna sensor | 50 |
| BANT Boom and preamplifier | 100 |
| Σ | 1680 (Aluminium box) |
| Harness | Mass gram/meter |
| E (vector) | 50 |
| B (one component) | 25 |



Telemetry Requirements

| Parameter | Fast | Slow | Very slow | Ultra slow |
|-----------|--------|-------|-----------|------------|
| E_1 | 32768 | 2560 | 192 | 0 |
| E_2 | 32768 | 2560 | 192 | 0 |
| E_3 | 32768 | 2560 | 192 | 0 |
| B | 32768 | 2560 | 192 | 0 |
| HK | 8 | 8 | 8 | 8 |
| Sum (bps) | 131080 | 10248 | 776 | 8 |

ELVIS – ELectromagnetic Vector Information Sensor

J. E. S. Bergman¹, L. Åhlén¹, O. Stål¹, B. Thidé^{1,2},
S. Ananthkrishnan⁴, J.-E. Wahlund¹, R. L. Karlsson¹,
W. Puccio¹, T. D. Carozzi³, and P. Kale⁵

¹ Swedish Institute of Space Physics, Uppsala, Sweden

² LOIS Space Centre, Växjö University, Växjö, Sweden

³ Space Science Centre, Sussex University, Brighton, UK

⁴ National Centre for Radio Astrophysics,
Tata Institute of Fundamental Research
Pune University Campus, Ganeshkhind, Pune, India

⁵ Integrated Circuit and information Technology Pvt. Ltd,
Department of Electronic Science,
University of Pune, Ganeshkhind, Pune, India

Summary

The ELVIS instrument was recently proposed by the authors for the Indian Chandrayaan-1 mission to the Moon and is presently under consideration by the Indian Space Research Organisation (ISRO). The scientific objective of ELVIS is to explore the electromagnetic environment of the moon. ELVIS samples the full three-dimensional (3D) electric field vector, $\mathbf{E}(\mathbf{x},t)$, up to 18 MHz, with selective Nyquist frequency bandwidths down to 5 kHz, and one component of the magnetic field vector, $\mathbf{B}(\mathbf{x},t)$, from a few Hz up to 100 kHz. As a transient detector, ELVIS is capable of detecting pulses with a minimum pulse width of 5 ns. The instrument comprises three orthogonal electric dipole antennas, one magnetic search coil antenna and a four-channel digital sampling system, utilising flexible digital down conversion and filtering together with state-of-the-art onboard digital signal processing.

The ELVIS Instrument

Vector measurements are critical for an unambiguous characterisation of electromagnetic fields and their polarisation [1], including wave direction finding. Therefore, ELVIS comprises three, 5 m long, electric dipole antennas, mounted on the satellite body in an as close as possible orthogonal configuration. Each dipole is

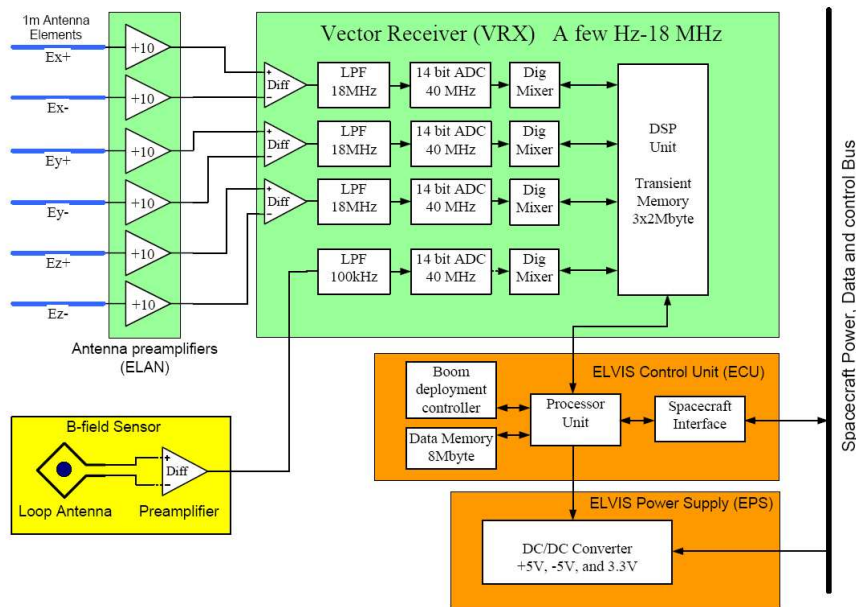

Figure 1: ELVIS block diagram

connected to a digital receiver, which allows for detailed investigation of electric field vector fluctuations up to 18 MHz. As a transient detector, ELVIS has a time resolution of 12.5 ns and a detection limit of 5 ns. For high-sensitivity measurements below 100 kHz, a magnetic search-coil antenna, measuring one component of the magnetic field vector, is connected to a fourth, identical, digital receiver. Fig. 1 illustrates schematically the functionality of the ELVIS instrument.

One electric dipole antenna is created by connecting two active, 2.5 m long, monopole antennas to a differential amplifier. The digital receiver then contains three stages: The first stage is an analogue anti-aliasing filter. Lowpass, 19th order, Chebyshev filters have been chosen here. The second stage comprises the analogue-to-digital conversion (ADC). Synchronised, high speed 14 bit ADCs with a sampling frequency of 40 MHz are used. Operated as a transient detector the anti-aliasing filters are bypassed and the ADC sampling frequency is doubled to 80 MHz. The ADCs are limited to 500 MHz input frequency, but it is the ELVIS low-noise antenna pre-amplifiers (ELNA) that limits the detectability. This limit is 200 MHz, corresponding to 5 ns pulses. The third stage of the receiver is a four-channel digital downconverter (DDC). The DDC is the core of ELVIS, as it digitally performs all traditional, analogue, receiver functions. It is a, so-called, *hard-wired* digital signal processor (DSP), which is optimised to perform digital frequency mixing, filtering and sampling-rate reduction. Reduction factors between 1 (full bandwidth) and 4096 can be used. This is reflected in the dynamic range of ELVIS, which is 81–84

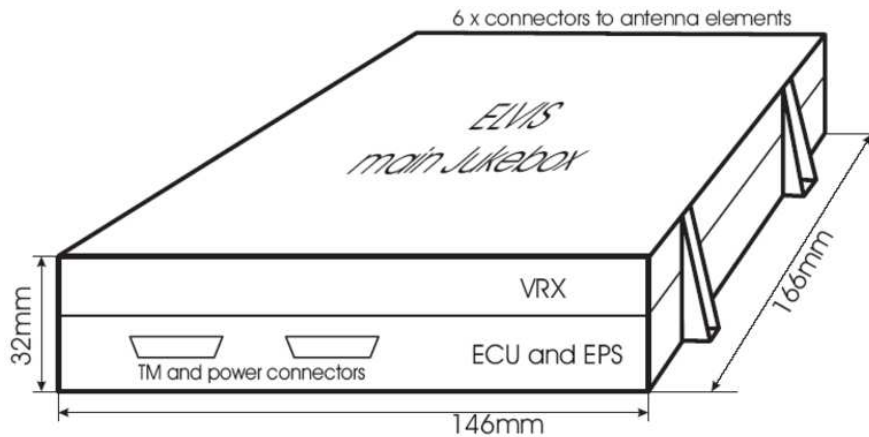

Figure 2: ELVIS main electronics box (JUKEBOX)

dB (14 bits) at full bandwidth and 117–120 dB (20 bits) at a reduction of 4096, corresponding to 5 kHz bandwidth at 40 MHz sampling frequency. Nominally, ELVIS has a sensitivity of -135 dBm/Hz. An additional DSP for data post-processing and a 3×2 MB transient memory makes up the full vector receiver (VRX), which uses one printed circuit board (PCB). A second PCB houses the ELVIS controller unit (ECU), and power supply (EPS). The ECU is the only control and data interface to the spacecraft. For the Chandrayaan-1 mission, the ELVIS telemetry requirement is 128 kbps. Besides the processor unit the ECU contains a dedicated boom deployment controller and 8 MB of memory for processed data. The EPS is a DC/DC converter that supplies +5V, -5V and 3.3V to ELVIS and it is the only power interface to the spacecraft. Normally, ELVIS requires 4W of power but during transient detection this is increased to 7W. A peak value of 10W is expected during short periods.

Mechanically, the VRX and the combined ECU/EPS PCBs are housed in the ELVIS main electronics box (JUKEBOX), as shown in Fig. 2. The JUKEBOX is made of two NCN-milled aluminium frames and measures $166 \times 146 \times 32 \text{ mm}^3$. The base plates are 0.5 mm thick with 4 mm thick stiffening covering 20 % of the box surface area. The mass of the complete electronics box, including PCBs, screws and connectors, is 630 gram. The six electric antenna elements (EANT) are made of a metal foil that is stored on a reel and forms 2.5 m long tubular booms when deployed. The mass of one unit is 150 grams, with the antenna tube itself weighing less than 50 grams. To reduce the magnetic contamination from instruments and systems onboard the spacecraft, the search coil sensor will be installed on the top of a deployable rigid boom, at a minimum distance of 500 mm from the spacecraft. For deployment, the boom has a bellow hinge that is filled with a low melting-point metal. A heater is used to melt the metal and operate the hinge. The mass of the search-coil sensor, including the boom unit, is 150 grams. The total mass of the

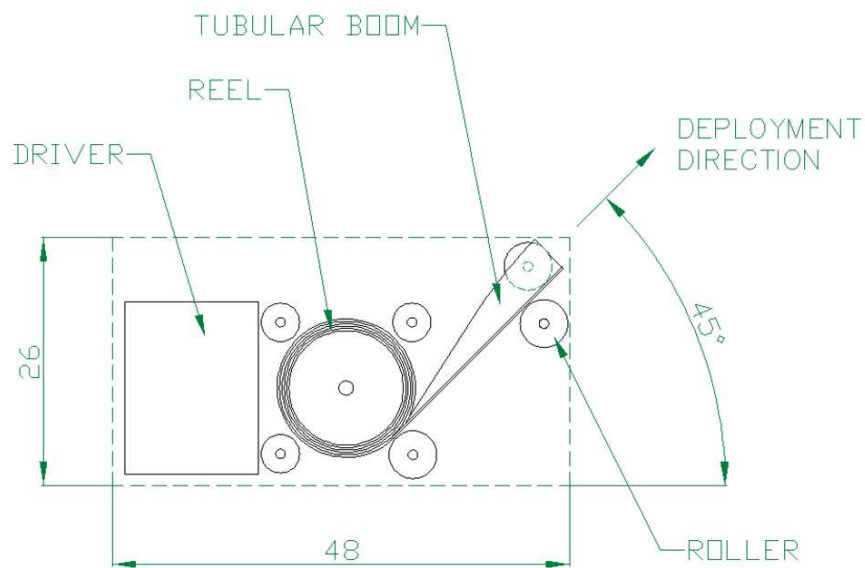

Figure 3: Electric Antenna deployment unit (NanoSpace-1 design by J. Grygorczuk, Space Research Centre, Warsaw, Poland). Scale in mm.

ELVIS instrument is 1630 grams, excluding cable harness.

At a cost of performance, using shorter antennas the ELVIS mass can be reduced quite substantially. On the Swedish NanoSpace-1 (NS1) nanosatellite, 1 m antenna elements, weighing only 25 grams each, will be used, see Fig. 3. For ELVIS on-board Chandrayaan-1 that would save 750 grams. Another 100 grams can be saved by using Mg rather than Al as material for the JUKEBOX. Together, these savings gives a total mass of 730 grams. To further reduce mass significantly, one has to replace the PCB electronics. One alternative that we will use on NS1 is a so-called *multi chip module* (MCM), where naked electronics chips are embedded directly in a single Silicon wafer. In this case a 7×7 cm² wafer with a mass of 25 grams is used to accommodate ELVIS and three other instruments.

Scientific Objectives

A thorough knowledge of the electromagnetic environment of the Moon is a necessity before low-frequency radio observations from the Moon can be realised, which is our long-term goal. The scientific objective of ELVIS is therefore to explore the electromagnetic environment of the Moon. To this end, investigations of the electromagnetic field properties, their sources and origins will be carried out.

Radio measurements are very efficient and versatile and can be used to study the Moon *itself* and its interaction with the surrounding space plasma and solar wind.

For studies of remote radio sources, including radio astronomy, using the Moon as a *shield*, the far side of the Moon is the most radio quiet site within reach in our solar system. That is why a low frequency radio telescope on the far side of the Moon has been a dream for many decades. Using instead the moon as a *target*, there are also more exotic emissions of cosmic origin that remains to be studied. Of particular interest are those caused by ultra-high energy neutrinos impinging upon the lunar surface, which give rise to transient radio pulses through the Askaryan effect [1]. Such pulses can be detected by ELVIS.

Lunar Space Plasma

A whole range of unexplored plasma phenomena are foreseen in the neighbourhood of the Moon. Most of our knowledge of the lunar plasma comes from a lunar wake passage at $6.5 R_L$ by the WIND spacecraft on Dec. 27, 1994 [2–5]. The WIND observations revealed a lunar wake density cavity with an electron density below 0.2 cm^{-3} , where there existed a heated electron population of up to a few 100 eV, as well as a cross wake ion flow.

The cross wake current has to close somewhere near the Moon. One possibility is that electric currents are carried by a dense photo electron layer [6–8] near the day-side lunar surface. A most interesting aspect of the solar wind – Moon interactions observed by WIND was the detection of a multitude of plasma and radio emissions in the lunar wake as well as in the wake lobes [5]. The radio emissions observed inside the wake matched the electron plasma frequency observed at its edges. (The angular electron plasma frequency in SI units is given by $\omega_{pe} = \sqrt{q_e^2 n / \epsilon_0 m_e}$, where n is the number density in m^3 .) It is believed that these radio emissions originate in the turbulent plasma near the edges of the wake.

When the Moon passes the night side of the Earth, measurements can be made of the properties of the geomagnetic tail, preferably in coordination with other magnetospheric satellites. An ELVIS instrument in orbit around the Moon can detect large-scale plasma cavities when these, as a result of geomagnetic storms, move outward in the magnetospheric tail and pass the Moon. What effect the Moon plasma itself has on the geomagnetic tail and the near Earth magnetospheric processes is not known. If a well developed lunar ionospheric plasma exists, significant effects on the geomagnetic tail is expected because this plasma will act both as a mass load and as a diversion of electrical currents in the tail.

There appears to exist mini-magnetospheres on the Moon, as shown recently [9]. It is believed that these are caused by local magnetic anomalies in the lunar crust. This gives rise to the possibility of small scale shocks, which could be potentially active sites for wave – particle interaction processes and radio emissions [10]. Such radio emissions could be detectable by ELVIS, thus verifying the presence of the mini-magnetospheres.

LOFAR/LOIS and Radio Observatories on the Moon

A gigantic network of sensors for astronomy, space and environmental studies is being built in Europe. Sweden has been part of this cooperation for several years by contributing with sensor, IT and radio research, as well as a test compound in southern Sweden. The heart of this trans-European sensor network is LOFAR [www.lofar.org], currently being built in the Netherlands. Data streams at up to Terabits per second from tens of thousands of small, inexpensive sensors, placed in an area about 300 km across, and connected by fibre-optic networks, are processed in powerful supercomputers. This results in the world's most sensitive radio telescope in the hitherto unexplored lowest frequency band 10-250 MHz. In addition to space research, the sensor network will be used for geophysics, agricultural and environmental research and as a test-bed for future wireless and optical fibre networks.

The LOIS [www.lois-space.net] subproject was born in 2000. The objective is to build a space-, telecom- and IT-research supplement to LOFAR in southern Sweden. The LOFAR/LOIS combination will be a next-generation network-based radar for solar system studies that will provide opportunities to make research at the cutting edge of radio-based space science.

A low-frequency lunar radio telescope would be realised using a modern phased array concept, pioneered in Europe by LOFAR/LOIS, consisting of about 100 light-weight tripole antennas connected by a wide area sensor network.

The ELVIS instrument can demonstrate the performance of one such antenna and act as a precursor for a lunar radio observatory. In addition, coordinated measurements with ELVIS and LOFAR/LOIS would be able to produce scientific results of high significant value.

Ultra-high Energy Neutrino Detection

As described in a companion paper [11], ELVIS could potentially detect radio emissions caused by ultra-high energy neutrinos hitting the Moon. Neutrinos are difficult to detect since they interact with matter only through weak processes with low cross-section. To access the decreasing flux of ultra-high energy (UHE) cosmic neutrinos with an energy far above 1 PeV, target volumes well in excess of 1 km³ are required. Askaryan proposed early [12; 13] that, for these energies, it might be advantageous to look for the coherent, radio frequency, Vavilov-Čerenkov emission. The coherent emission is generated by a negative charge excess in the showers of secondary particles that is produced when the neutrino interacts with a dense material [12; 14].

Such interactions should take place in the lunar regolith, and searches for Askaryan pulses have been performed using radio telescopes on Earth [15]. We believe that such pulses could be detectable by the ELVIS instrument, considering especially the 70 dB gain the closer distance to the moon provides compared to Earth-based observations. Simulations on the expected detection efficiency for UHE neutrino events have been performed [11], showing a neutrino energy threshold of 5×10^{19}

eV and a model dependent expected event rate of 2.2 detectable events per year of observation time.

Measurement Principles

To describe electromagnetic waves, an analytic representation in terms of complex valued three-dimensional electric and magnetic vector fields, $\mathbf{E}(\mathbf{x}, t)$ and $\mathbf{B}(\mathbf{x}, t)$, respectively is convenient. The analytic representation has several advantages, and is the natural choice for physicists as well as radio engineers. In ELVIS, the analytic representation is obtained in the DDC, which outputs complex time-series, in terms of 16 bit in-phase and quadrature-phase (I, Q), components.

In general, by polarisation we mean the 2nd order statistics of any combination [16] of the complex field vectors \mathbf{E} and \mathbf{B} . ELVIS measures only \mathbf{E} , and therefore the coherency (or spectral) density matrix can be used:

$$\mathbf{E}\mathbf{E}^\dagger = \begin{pmatrix} E_x E_x^* & E_x E_y^* & E_x E_z^* \\ E_y E_x^* & E_y E_y^* & E_y E_z^* \\ E_z E_x^* & E_z E_y^* & E_z E_z^* \end{pmatrix} \quad (1)$$

This matrix completely describes \mathbf{E} -field polarisation in 3D and is a generalisation [1] of Stokes 2D description. For instance, the intensity, $\mathbf{E} \cdot \mathbf{E}^*$, is the trace and the imaginary part of the off-diagonal elements yields a vector, $i\mathbf{E} \times \mathbf{E}^*$, that in vacuum is parallel to the direction of wave propagation. Furthermore, a measure of the degree of circular polarisation is given by the ratio $|i\mathbf{E} \times \mathbf{E}^*|/|\mathbf{E} \cdot \mathbf{E}^*|$. In 3D there are altogether five independent instantaneous polarisation parameters. By taking averages of the matrix in (1) the full set of nine polarisation parameters can be used. In 2D, these parameters reduces to the four well-known Stokes parameters.

Sampling at 40 MHz, ELVIS will produce 2 Gbps of raw data. Clearly, this huge data rate must be reduced. A major reduction, down to 1 Mbps at 5 kHz bandwidth can be performed by the DDC but this is not enough. Post processing of data in the DSP is therefore necessary. The post processing is a trade-off between time, frequency and polarisation coverage. On ELVIS, the field entropy is calculated regularly and passed to housekeeping (HK) data. Entropy is a measure of information that can be used to turn on and off different modes according to pre-defined rules. It can also be used as a signal for other instruments onboard the spacecraft.

ELVIS operates in four basic modes: Survey Mode (SM), Normal Mode (NM) Burst Mode (BM), and Transient Mode (TM). The time allocation for these modes are 60%, 15%, 15%, and 10%, respectively. In SM, ELVIS performs narrowband frequency sweeps and in NM it operates as a baseband I/Q receiver. The BM and TM are similar, capturing the full bandwidth waveform, but in TM the sampling frequency is doubled to 80 MHz and the Nyquist filters are bypassed. Only those events identified as transients are stored.

Discussion

The design philosophy of ELVIS is to eliminate all unnecessary analogue electronics. The receiver functionality is instead performed digitally. This minimises signal distortion, reduces mass and makes the instrument more robust compared to analogue designs. However, the major advantage of ELVIS lies in its high flexibility, which makes it possible to address the broad spectrum of scientific objectives outlined here, including lunar space plasma studies, remote sensing, and ultra-high energy neutrino detection.

ELVIS builds on the heritage of proven space science instruments constructed at the Swedish Institute of Space Physics (IRF) in Uppsala, which currently has instruments in operation onboard six satellites. These are the four ESA Cluster satellites, the NASA Cassini spacecraft, and the ESA Rosetta spacecraft. ELVIS itself has no flight-record yet but will have very soon. A one-channel version will be launched before the end of 2005 onboard the Russian Compass-2 satellite, aimed at investigating precursors to earthquakes. A similar instrument but with three channels, will be installed by the end of 2006 on the International Space Station (ISS), for monitoring the ISS space environment. Eight digital vector receivers, identical to the ISS receiver, are since 2004 in operation at the LOIS Test Station in Växjö, Sweden. An equivalent receiver at IRF in Uppsala, has worked flawlessly in an outdoor setting for more than three years. A miniaturised ELVIS instrument MCM is also being developed for the Swedish NanoSpace-1 satellite to be launched in 2007–2008. To be selected for future grand missions, our strategy is to gain flight-experience onboard low-cost microsatellites. One satellite per year is foreseen in the next few years.

References

- [1] T. D. Carozzi, R. L. Karlsson, and J. E. S. Bergman, *Phys. Rev. E* **61**, 2024 (2000).
- [2] K. W. Ogilvie *et al.*, *Geophys. Res. Lett.* **23**, 1255 (1996).
- [3] J. M. Bosqued *et al.*, *Geophys. Res. Lett.* **23**, 1259 (1996).
- [4] C. J. Owen *et al.*, *Geophys. Res. Lett.* **23**, 1263 (1996).
- [5] P. J. Kellogg *et al.*, *Geophys. Res. Lett.* **23**, 1267 (1996).
- [6] A. S. Vyshlov, *Space Research* **XVI**, 945 (1976).
- [7] A. S. Vyshlov and N. A. Savich, *Kosmicheskie Issledovaniia* **16**, 551 (1978).
- [8] S. J. Bauer, *Anzeiger Abt II*, 17 (1996).
- [9] Y. Futaana *et al.*, *J. Geophys. Res.* **108**, 1025 (2003).
- [10] Z. Kuncic and I. H. Cairns, *Geophys. Res. Lett.* **31**, 809 (2004).
- [11] O. Stål *et al.*, in *Proc. of the DGLR Int. Symp. To Moon and Beyond* (To be published, see also arXiv:astro-ph/0509210, Bremen, Germany, 2005).
- [12] G. Askaryan, *JETP* **14**, 441 (1962).
- [13] G. Askaryan, *Phys. Rev. Lett.* **21**, 658 (1965).
- [14] D. Saltzberg *et al.*, *Phys. Rev. Lett.* **86**, 2802 (2001).
- [15] P. W. Gorham *et al.*, *Phys. Rev. Lett.* **93**, 041101 (2004).
- [16] T. D. Carozzi and J. E. S. Bergman, arXiv:math-ph/0509019 (2005).